

# FLASHING GUIDE

FOR ARCHITECTS AND DETAILING  
PROFESSIONALS

# LYSAGHT




## Table of Contents

<b>1. Introduction and Scope</b>	<b>3</b>
<b>2. Design Preliminaries</b>	<b>4</b>
2.1 Product selection	4
2.2 The purpose of flashing	4
2.3 Materials and finishes	5
2.4 Compatibility	5
2.5 Support spacings	6
2.6 Maximum lengths of roofing	6
2.7 Low roof pitches	6
2.8 Wind forces on roofs	6
2.9 Codes and performance tests	6
2.10 Specifications - roofing profiles	7
2.11 Specifications - walling profiles	8
<b>3. Roof flashings</b>	<b>9</b>
3.1 Design	9
3.2 Roof flashings	10
3.3 Flashing laps	11
3.4 Apron flashing	11
3.5 Longitudinal flashings	11
3.6 Transverse flashings	12
3.7 Using notching tools	13
3.8 Flashing at change of pitch	14
3.9 Capped bent roofs	14
3.10 Gutter apron	15
3.11 Types of penetration flashing design	16
3.12 Flashing large roof penetrations	17
3.13 Flashing small roof penetrations	19
3.14 Expansion	20
3.15 Standard roof flashings	21
3.16 Non standard roof flashings, cappings	24
3.17 Box gutters	25
3.18 Barge gutters and capping	26
<b>4. Typical wall flashings</b>	<b>27</b>
4.1 Cladding orientation	27
4.2 Walling profile running horizontally	27
4.3 Types of flashings	28
4.4 Optional wall trims	29
4.5 Mid-wall connections	30
4.6 Internal wall connections	30
4.7 External corner connections	31
4.8 Flashing for horizontal cladding	31
4.9 Flashing for horizontal corrugate cladding	32
4.10 Flashings for vertical cladding	32
4.11 Toe-Mould Type Flashing	33
4.12 Window flashing types	33
4.13 Window flashings for metal cladding	33
4.14 Flush window flashings	34
4.15 Recessed window flashings	36
4.16 Butt window flashings	37

## Copyright


Copyright in this information including any designs, text, data, graphics and images belong to BlueScope Steel Ltd, trading as Lysaght except as noted.

Thanks are given to the New Zealand Metal Roofing Manufacturers Inc. For permission to reproduce text, graphics and drawings from their copyright publication - NZ METAL ROOF AND WALL CLADDING CODE OF PRACTICE (Version 2.2: 2012). All rights reserved. Such material is annotated in footnotes as such by use of this logo. 

Any use of this publication including reproduction, modification, distribution or re-publication, in whole or in part\*, in any form or medium, without written permission of Lysaght is prohibited.

© Copyright BlueScope Steel Limited April 7, 2014

Produced at Lysaght Research & Technology

 \* Except for material taken from NZ METAL ROOF AND WALL CLADDING CODE OF PRACTICE (Version 3: 2012) where the permission of the New Zealand Metal Roofing Manufacturers Inc. must be sought.

# 1. Introduction and Scope

- How to design and detail steel clad roofs and walls
- Clear, concise installation tips and methods for architects and draftsmen
- Using flashings to create an architectural feature
- Industry 'best practice' explained

Correct detailing of LYSAGHT roof and wall flashing has more than cosmetic importance - it is essential in ensuring the wet weather performance of the cladding.

Correct flashing and detailing will improve the overall appearance of the finished job.

The advice given in this manual is consistent with the requirements of the Building Code of Australia and is aimed at ensuring that correct practice is specified into building construction.

In many instances, alternative methods are examined to provide a clear understanding of the implications arising from these alternatives.

And finally, the examples shown are typical of the work to be carried out and may not apply to specific situations or specific LYSAGHT cladding products. In all cases, a qualified tradesman should be engaged to ensure the advice given here is applicable to your intended use.

We hope that the information supplied provides clear, concise direction in the correct design and detailing of roof and wall flashing for architects and draftsmen.

The manual is set out in two parts, design and flashing.

For overall roof and wall design, refer to the LYSAGHT Roofing & Walling Installation Manual. If these products are to be used in cyclonic areas as defined in AS 1170.2:2011, you must also refer to the Lysaght Cyclonic Area Design Manual.

Both these publications are available at:  
[www.lysaght.com](http://www.lysaght.com)



## 2 Design preliminaries

### 2.1 Product selection

When you incorporate steel cladding into your building LYSAGHT offers a wide range of profiles from which to choose. Whilst roofing and walling obviously have to keep out the weather, they also have significant effects on the looks, cost and durability of a building.

If you are unsure about any product feature, visit [www.lysaght.com](http://www.lysaght.com), call our information line or seek advice from the relevant specialists.

Lysaght has been supplying the Australian building industry with premium products for over 150 years, and our technical literature provides the engineering data to design buildings using our products.

In particular, architects and builders should consult chapters 2 to 6 of the LYSAGHT Roofing & Walling Installation Manual. We urge the reader to consult this document for overall design and fixing advice, although selected parts of that information are repeated here.

The appropriate design will depend on your particular needs and circumstances. You should get advice from the relevant qualified specialists where required.

### 2.2 Purpose of flashing

The purpose of a flashing is to make the building weather-resistant and to prevent water from entering the building by diverting it.

Flashings and cappings are strips of metal formed to weatherproof the edges of roofing and walling. For the purposes of this chapter, only the term flashing is used. The following sections should be considered as a guide only. For a comprehensive account of flashing guidelines, refer to HB39-1997.

Similar methods of flashing are used for different cladding-profiles. You can adapt the principles to suit your application.

In all cases it is important to have ample cover provided by the flashing and proper turn-up of the cladding underneath.

Be careful when moving between supports. Do not walk in the pan immediately adjacent to flashings or translucent sheeting. Walk at least one pan away.

Lysaght has a range of standard flashings. We can also supply custom flashings to your requirements – ask your local service centre for details.

Flashings are required to provide weather-resistance for the various junctions on a roof or wall structure. Flashings are an important part of the cladding design, and have a significant impact on the aesthetic appearance of the building.

Qualified tradesmen or other suitable expertise should be sought when designing, cutting and fastening flashing to a building.

Ponding of water and build-up of debris should be prevented and all flashings should be designed to prevent this from happening. Flashings must be designed to provide weather-resistance for the roof or wall cladding, independent of the use of sealants or other materials to provide such weather-resistance.

Unpainted galvanised steel is incompatible with most inert materials and is subject to inert catchment corrosion.

### 2.3 Materials and finishes

Flashings, ridge cappings, and accessories should be made from the same material as the material used to clad the roof or walls. If different materials are intended or specified, such materials should be compatible for both contact and run-off. Our most widely used cladding profiles are listed in Tables 2.10.1 and 2.11.1. They are available in COLORBOND® pre-painted steel, or in unpainted ZINCALUME® aluminium/zinc alloy-coated steel.



## Typical material specifications

- COLORBOND® is pre-painted steel for exterior roofing and walling. It is the most widely used. The painting complies with AS/NZS 2728:2013 and the steel base is an aluminium/zinc alloy-coated steel complying with AS 1397:2001. Minimum yield strengths are G550 (550MPa), or G300 (300MPa) depending on the profile. Minimum coating mass is AM100 (100g/m<sup>2</sup>).
- COLORBOND® ULTRA is pre-painted steel for severe coastal or industrial environments (generally within about 100-200 metres of the source). The painting complies with AS/NZS 2728:2013 and the steel base is an aluminium/zinc alloy-coated steel complying with AS 1397:2001. Minimum yield strength is G550 (550MPa). Minimum coating mass is AM150 (150g/m<sup>2</sup>).
- Stainless steel standard grade designation is AISI/ASTM Type 430; UNS No. S43000

Not available in metallic finishes as a standard item. Subject to enquiry.

The COLORBOND® pre-painted steel complies with AS/NZS2728:2013.

Check with your local BlueScope Lysaght office for availability of profiles, materials, finishes, colours, accessories; and for suitability of the product.

Tables 2.10.1 and 2.11.1 list general information for profile selection. Refer to our publications on specific products for detailed specifications. There are also publications on ZINCALUME® steel and COLORBOND® pre-painted steel from our information line (Page 1).

## 2.4 Compatibility

Contact with, or runoff from, some materials can damage coated steel products. Buildings can also be susceptible to condensation on inside surfaces. The materials include certain metals, treated timbers and chemicals.

- Don't allow any contact of coated steel products with incompatible materials.
- Don't allow discharge of rainwater from incompatible materials onto coated steel products.
- Ensure that supporting members are compatible with the coated steel products or, alternatively, appropriately coated.

Incompatible materials include: lead, copper, monel metal, bare steel, stainless steel (except with COLORBOND® stainless cladding), carbon (in pencils and some rubbers), green or some chemically-treated timber (like CCA or tanalith treatments), materials subject to cycles of dryness and wetness or which have excessive moisture content (such as improperly-seasoned timber), wet and dry concrete, soils, vegetable matter, cleaning agents (e.g. brick cleaning) and any material which will inhibit normal exposure to the atmosphere.

When moisture is present and two dissimilar metals are in contact, accelerated galvanic corrosion can affect one of the surfaces. This type of corrosion can also occur when water flows over dissimilar metals.

Properly designed flashings help to keep the cladding dry and help to divert moisture and debris away from joints. To avoid ponding, all flashings should have a minimum fall of 1.5°.

Roofers and designers should consider compatibility issues when selecting materials in a roof or wall system. Furthermore placing solar collectors, air-conditioning units

or walkways on top of roof cladding need to consider discharge from such systems. Severe corrosion may occur if materials are not combined correctly.

Lead flashing is not recommended, however it will usually be retained when re-roofing, because it is usually cemented into the structure. In these cases:

- the top surface of the lead flashing must be painted with a good quality exterior paint system (to limit contamination with lead compounds in water running off the flashing); and
- there must be a barrier between the lead flashing and the cladding: either a plastic strip (such as polyethylene damp course), or paint.

Flashings should conform to AS/NZS 2179.1:1994, and be compatible with the cladding (Section 2.10, LYSAGHT Roofing & Walling Installation Manual).

Materials for flashings are available in ZINCALUME® or COLORBOND® finishes.

## 2.5 Support spacings

The maximum recommended support spacings are shown in Tables 2.13.1 and 2.14.1 of the LYSAGHT Roofing and Walling Installation Manual. They are based on data in accordance with AS 1562.1:1992 Design and installation of sheet roof and wall cladding: Metal, and AS 4040.1:1992 Methods of testing sheet roof and wall cladding—Resistance to concentrated loads.

The spacings in the tables are recommended to produce adequate performance of claddings under concentrated loading (incidental for maintenance).

For support spacings in wind conditions, refer to our publications on specific products for wind pressure data.

In all cases, cladding is fixed to a support of 1.0mm minimum base metal thickness (BMT) and minimum yield stress of 550MPa. If you want to use metal battens thinner than 1.0mm, seek advice from our information line.

## 2.6 Maximum lengths of roofing

The valleys (or pans) of roofing have to carry water to the gutters. If the valleys overflow in heavy rain, water can flow into the roof through the side-laps and flashings.

Factors affecting waterproof and drainage capacity of the laps of a profile include:

- the width and depth of the valleys or pans;
- the pitch of the roof—rain flows faster on a steeper pitch;
- rainfall intensity for the geographical area;
- the length of the roof from ridge to gutter; and
- penetrations that cause nearby valleys to carry extra rain diverted from valleys obstructed by the penetration (Figure 2.14.1).

The maximum recommended roof lengths for drainage for each profile are given in Table 2.14.1 of the LYSAGHT Roofing and Walling Installation Manual.

## 2.7 Low roof pitches

Unless there is adequate positive fall in a roof, there is danger of ponding, which can lead to a reduced service life, particularly in coastal areas.

At low slopes, say around 1 in 50 (1°) slope, all roof supports must be in the one plane because slight variations can result in zero or negative fall. This may occur even after completion of the building as the result of settlement, timber warping or shrinking, or extra loadings (like air conditioners).

Minimum recommended roof slopes are listed in Table 2.12.1 of the LYSAGHT Roofing and Walling Installation Manual. As a guide, wherever possible, you should design for a minimum slope of 1 in 30 (2°). Roof slopes lower than the recommended minimum may be available subject to enquiry and will be dependent upon the roof application and building details.

## 2.8 Wind forces on roofs

Winds create considerable forces on both the topside and the underside of roof cladding, and you must consider these forces in the design and fixing of any roof. The forces are:

- **inward forces** tending to collapse the roof cladding inwards, caused by wind acting directly on the windward side; and
- **outward forces** tending to lift the roof cladding from its framing, and the entire roof structure from the rest of the building. Outward forces can be caused both by uplift from negative wind pressures, outside the building; and by positive wind pressure inside the building.

Generally the greatest wind forces imposed on roofs are due to the outward forces. Because the dead weight of roofing materials is relatively small, the outward forces must be resisted by the roof fasteners.

It is very important that the battens and roof framing are adequately fixed to the rafters and walls, and that claddings and flashings also be fixed to withstand these pressures.

## 2.9 Codes and performance tests

AS 1562.1:1992 specifies the design and installation of sheet metal roof and wall cladding. Our roofing profiles satisfy all the requirements of this standard, including the ability of the roof to resist outward forces and concentrated loads. The testing is performed according to AS 4040.1:1992 and AS 4040.2:1992.











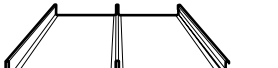



Flashings and cappings, although not tested separately, must comply to the fixing requirements of the cladding to deliver equal performance.

## 2.10 Specifications - roofing

**Table 2.10.1**

Specifications of roofing & walling profiles

Maximum recommended spacing of supports

	BMT mm	Mass <sup>1</sup> kg/m <sup>2</sup>	Cover width mm	Rib depth mm	Roof pitch minimum <sup>2</sup> degrees	Maximum recommended spacing of supports								
						ROOFS			Eaves Overhang <sup>3</sup>		WALLS			
						Single	End	Internal	Unstiff- ened	Stiff- ened	Single	End	Internal	Over- hang
mm	mm	mm	mm	mm	mm	mm	mm	mm	mm	mm	mm	mm	mm	
 CUSTOM ORB	0.42	4.3	762	16	5° (1 in 12)	700	900	1200	200	300	1800	2500	2700	200
	0.48	4.9	762	16	5° (1 in 12)	800	1300	1700	250	350	1800	2700	2700	250
 CUSTOM BLUE ORB	0.60	6.1	762	17	5° (1 in 12)	1600	1600	1800	200	300	2400	3000	3300	200
	0.80	8.0	762	17	5° (1 in 12)	1800	1800	2600	400	600	2400	3200	3600	400
 CUSTOM ORB ACCENT 21	0.40	4.4*	762	21	3° (1 in 20)	750	950	1350	150	400	1800	2400	2400	150
	0.48	5.2*	762	21	3° (1 in 20)	950	1500	1900	200	450	1800	2700	2700	200
 CUSTOM ORB ACCENT 35	0.48	5.5*	724	35	2° (1 in 30)	1300	1600	2400	200	600	2100	2700	2700	200
 FLATDEK <sup>5</sup>	0.42	6.0	250	45	2° (1 in 30)	2000	2600	3000	-	-	-	-	-	-
 FLATDEK II <sup>4</sup>	0.42	5.2	620	45	2° (1 in 30)	2400	2800	3200	-	-	-	-	-	-
 INTEGRITY 820	0.42	4.6	820	48	2° (1 in 30)	2100	2300	2800	150	300	2600	3400	3600	150
	0.48	5.2	820	48	1° (1 in 50)	2500	2550	3050	200	350	2700	3600	3600	200
 KLIP-LOK 406	0.48	5.6	406	41	1° (1 in 50)	1500	1800	2100	200	600	-	-	-	-
 KLIP-LOK 700 HI-STRENGTH	0.42	4.7	700	43	2° (1 in 30)	1650	1750	2200	150	450	2600	3200	3850	150
	0.48	5.3	700	43	1° (1 in 50)	2050	2350	2800	200	500	3000	3450	3900	200
	0.60	6.6	700	43	1° (1 in 50)	2350	3000	3600	250	550	3300	3600	3900	250
 KLIP-LOK CLASSIC 700	0.42	4.7	700	41	2° (1 in 30)	-	1800	2200	200	500	-	2150	3250	300
	0.48	5.3	700	41	1° (1 in 50)	-	2100	3050	250	600	-	2500	3550	400
 LONGLINE 305 (not tapered)	0.70	9.7	305	48	1° (1 in 50)	1800	2000	2500	150	450	-	2700	2700	450
 SPANDEK	0.42	4.7	700	24	3° (1 in 20) <sup>5</sup>	1300	1800	2400	300	600	2500	3000	3300	300
	0.48	5.3	700	24	3° (1 in 20) <sup>5</sup>	2000	2200	3000	400	700	3000	3000	3300	400
 SPANRIB	0.42	4.6	820	48	2° (1 in 30)	2100	2300	2800	150	300	2600	3400	3600	150
	0.48	5.2	820	48	1° (1 in 50)	2500	2550	3050	200	350	2700	3600	3600	200
 TRIMDEK	0.42	4.3	762	29	2° (1 in 30)	1100	1300	1900	150	300	2400	3000	3000	150
	0.48	4.9	762	29	2° (1 in 30)	1600	1850	2600	200	350	2700	3000	3000	200

<sup>1</sup> Masses are for unpainted ZINCALUME steel, unless otherwise marked (\*), \* which are indicative masses only.

<sup>2</sup> See Section 2.5, LYSAGHT Roofing & Walling Installation Manual.

<sup>3</sup> See Section 10.6 for explanation of 'stiffened'.

<sup>4</sup> FLATDEK & FLATDEK II are Home Improvement profiles.

Please refer to their individual brochures for more installation details.

<sup>5</sup> Slope of 2° (1 in 30) is available subject to enquiry. Please refer to Section 2.5, LYSAGHT Roofing & Walling Installation Manual.





# 3. Roof Flashing

## 3.1 Design

All roof cladding located at the join (except gutters), require a flashing fastened on both sides of the join.

Flashings near the edges of roofs or walls can be subjected to suction or negative wind loads that can be greater than other positive imposed loads. Therefore the wind design load can be approach double that of the main roof area, and as a result additional fixings are required to fasten flashings.

The design wind load of each structure determines the number and the spacing of flashing fasteners as well as locate wind zones on the building. A minimum number of fixings are required to avoid flexing fatigue cracking of metal cladding under changing loads. This also prevents noise or flapping.

Lysaght recommends screws instead of rivets for fastening flashings. The larger diameter of a screw shaft gives a greater shear capacity, and the larger head (or a washer) can be used to reduce the likelihood of pull out of the fastener.

The penetration of rain into the roof or wall through the flashings is largely caused by the air pressure differential between the outside and inside of the roof or wall.

Gusting wind can cause a significant pressure differential which can fluctuate greatly. This in turn can cause a pumping action where water can be sucked into the join which the flashing is protecting.

Solutions to this problem include an anti-capillary offset fold, a gap of up to 5mm, or a suitable sealant. All flashing edges require one of these measures to avoid capillary action where flashings are subject to wind action when in contact with the roof or wall cladding.

Flashings, other than standard ridging, are produced to specific order and are designed and manufactured from flat sheet or coil. If these flashings are required to match the colour of the profiled cladding sheets it is necessary for the pre-painted flat sheet or coil to be made by the same manufacturer using the same process in order to avoid differential colour matching or fading.

Preferred maximum length of flashing is 6m, with expansion joints provided after a maximum of two lengths of flashing (12m) have been fixed together, as any lap secured by rivets or screws effectively becomes one length.

Flashings are restricted in length in the same manner as are roof and wall cladding sheets and are subject to the same requirements and expansion provisions.

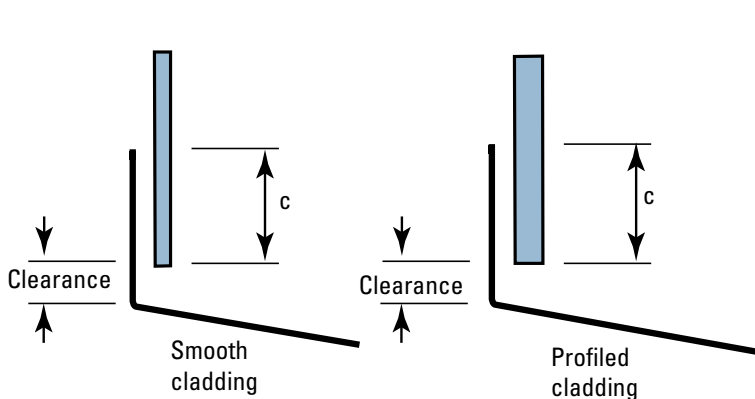
A minimum distance of 2-5mm from the edges of all flashings must be provided away from an adjacent horizontal surface. This helps avoid the retention of moisture and deterioration at the cut edge of flashings. When a cut edge is very close to some materials (concrete, plaster or some rubbers) this spacing is particularly important.

A minimum clearance (CL) of 25mm and a maximum clearance of 50mm should be provided at the end of wall cladding. The cladding should not extend down to any apron flashing.

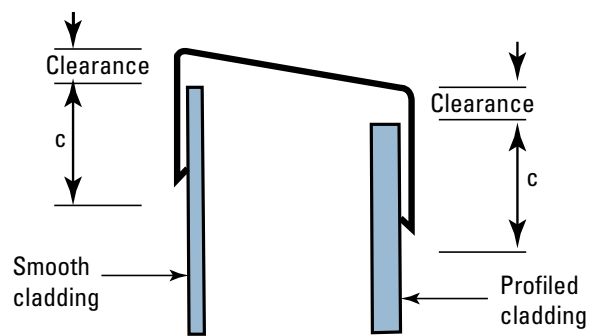


**Figure 3.1**  
Barge

C = Minimum cover  
Cl = Clearance



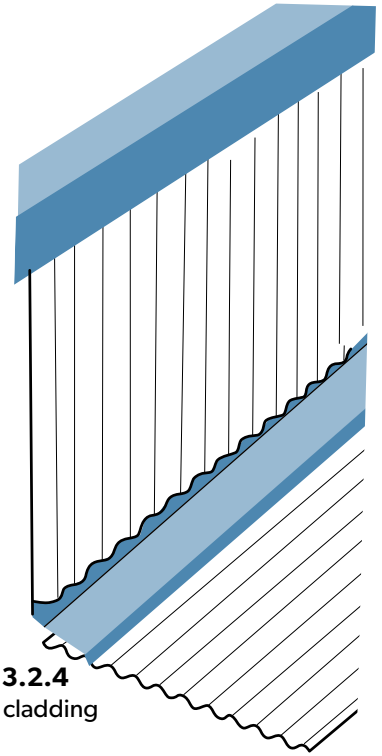
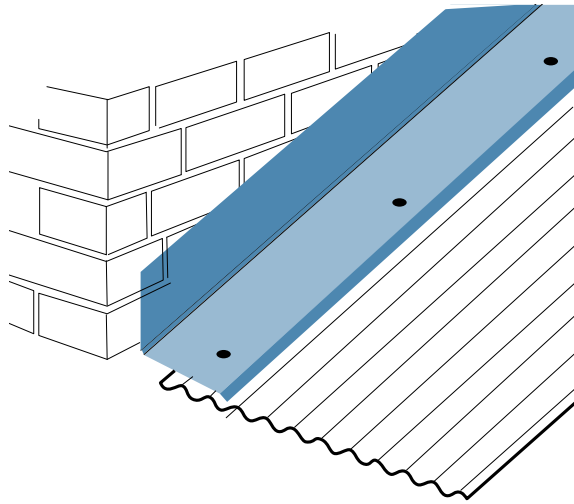
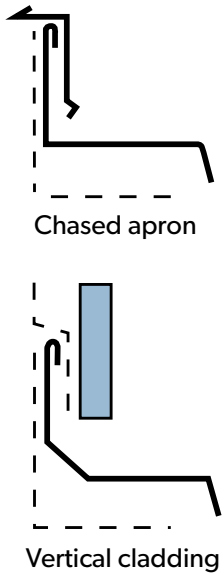
**Figure 3.1.2**  
Vertical apron



**Figure 3.1.3**  
Parapet

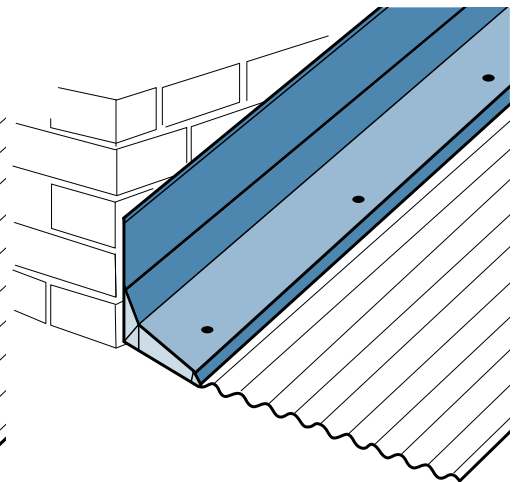
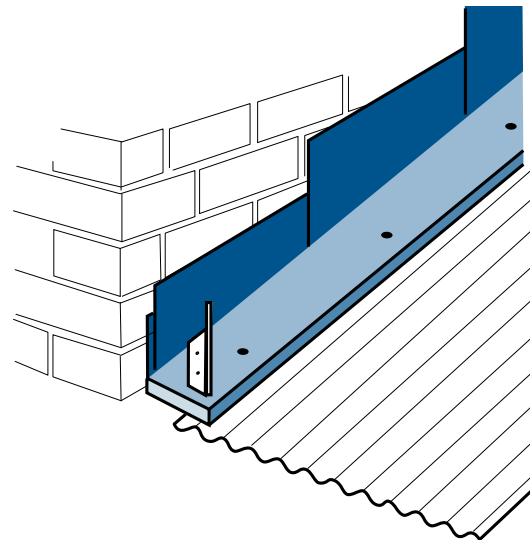
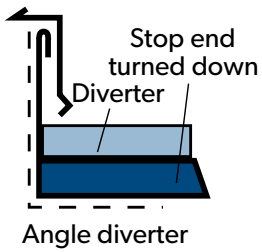
 These drawings are based on drawings from the NZ METAL ROOF AND WALL CLADDING CODE OF PRACTICE (Version 2.2: 2012).

### 3.2 Roof flashings



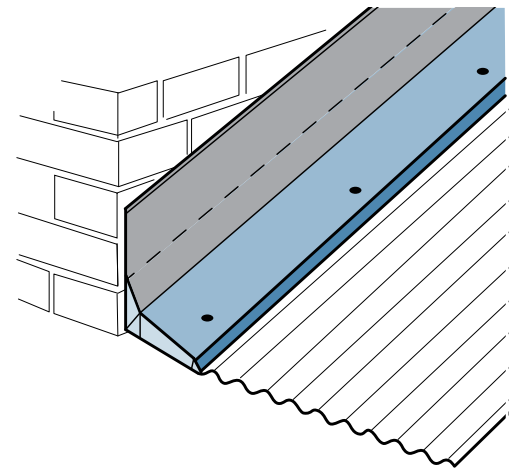
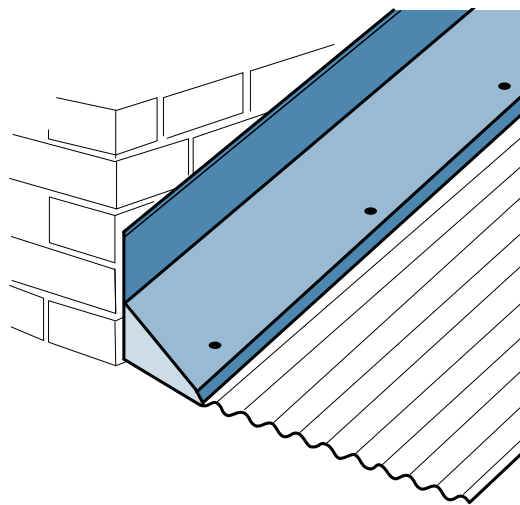
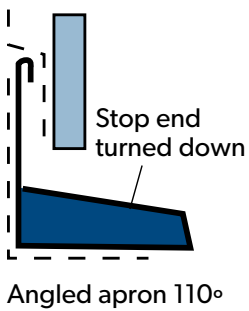
**Figure 3.2.1**  
Chased apron

**Figure 3.2.4**  
Vertical cladding



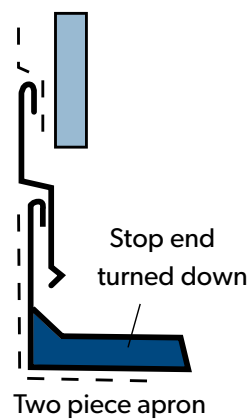
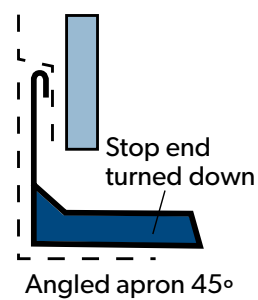
**Figure 3.2.2**  
Angle diverter

**Figure 3.2.5**  
Angled apron 110°



**Figure 3.2.3**  
Angled apron 45°

**Figure 3.2.6**  
Two piece apron



These drawings are based on drawings from the NZ METAL ROOF AND WALL CLADDING CODE OF PRACTICE (Version 2.2: 2012).

### 3.3 Flashing laps

A lap is the part of a flashing that covers (or overlaps) any part of the similarly shaped component, and these can be described as an end lap, overlap or underlap.

Laps should comply with the following criteria:

- an overlap must run over (not under);
- an overlap must run downhill (the direction of the water flow);
- water must flow over a lap (not into a lap);
- a lap must be self-draining (not relying on sealant);
- an overlap must be across the gradient or at a shallow angle;
- a lap must be mechanically (hard) fixed;
- a sealed lap must have a minimum of width of 25mm;

### 3.4 Apron flashing

Do not fit cladding tight onto the horizontal surface of an apron flashing. This would collect dirt and debris and it will retain moisture. A minimum clearance of 25mm is required.

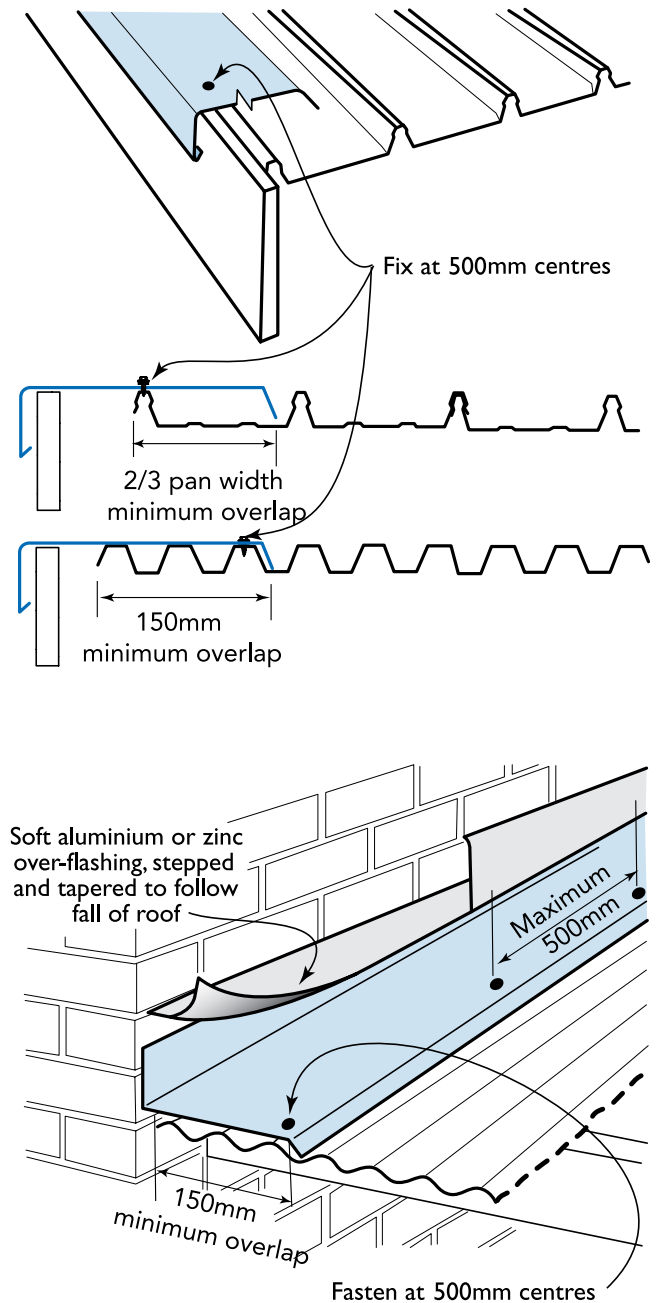
### 3.5 Longitudinal flashings

Longitudinal flashings run parallel to the pans or valleys, and are made to suit the cladding profile (Figure 3.5.1). They should have an edge turned-down to dip into the pan or valley.

#### Flashing Cover

The minimum recommended cover of longitudinal flashings over cladding should be as follows: (as taken from HB39-1997)

Pierce fixed roof sheet	150mm min.
Concealed fixed roof sheet	Into full pan (2/3 pan covered)



**Figure 3.5.1**  
Typical longitudinal flashings

### 3.6 Transverse flashings

Transverse flashings run across the pans or valleys (Figure 3.6.1). They usually have a stiffening lip, along the lower edge, which is turned-down to dip into the pan or valley. To maximise weatherproofing, the bent lip is profiled to fit.

The turn-down for transverse flashings for the shallow corrugated profiles can be fashioned to fit the profile by either notching or scribing to match the corrugations, or lightly dressed into the valleys. The type of fashioning (if any) depends upon profile shape and the type of material used to flash. Fashioning is preferred for low-slope roofs.

The turn-down for transverse flashings for wide panned cladding is always notched or scribed to fit over the ribs.

#### Flashing Cover

Lysaght produces a range of standard flashings (hip, barge, apron). To increase weather-resistance, Lysaght recommends you maximise the overlap between flashings and claddings. Refer to Table 8.1.2 in HB-39 for greater detail.

#### Fixing of Flashings

Longitudinal flashings shall be fastened at maximum 500mm centres. Transverse flashings shall be fastened in accordance with HB39-1997, as detailed below.

Profile	
Recommended Fixing Spacing (min.)	
CUSTOM ORB/CUSTOM BLUE ORB	Every 4th rib
CUSTOM ORB ACCENT 21	Every 4th rib
CUSTOM ORB ACCENT 35	Every 2nd rib
KLIP-LOK 406	Every rib
KLIP-LOK 700 HIGH STRENGTH	Every rib
KLIP-LOK CLASSIC 700	Every rib
LONGLINE 305	Every rib
SPANDEK	Every 3rd rib
SPANRIB	Every rib
TRIMDEK	Every rib

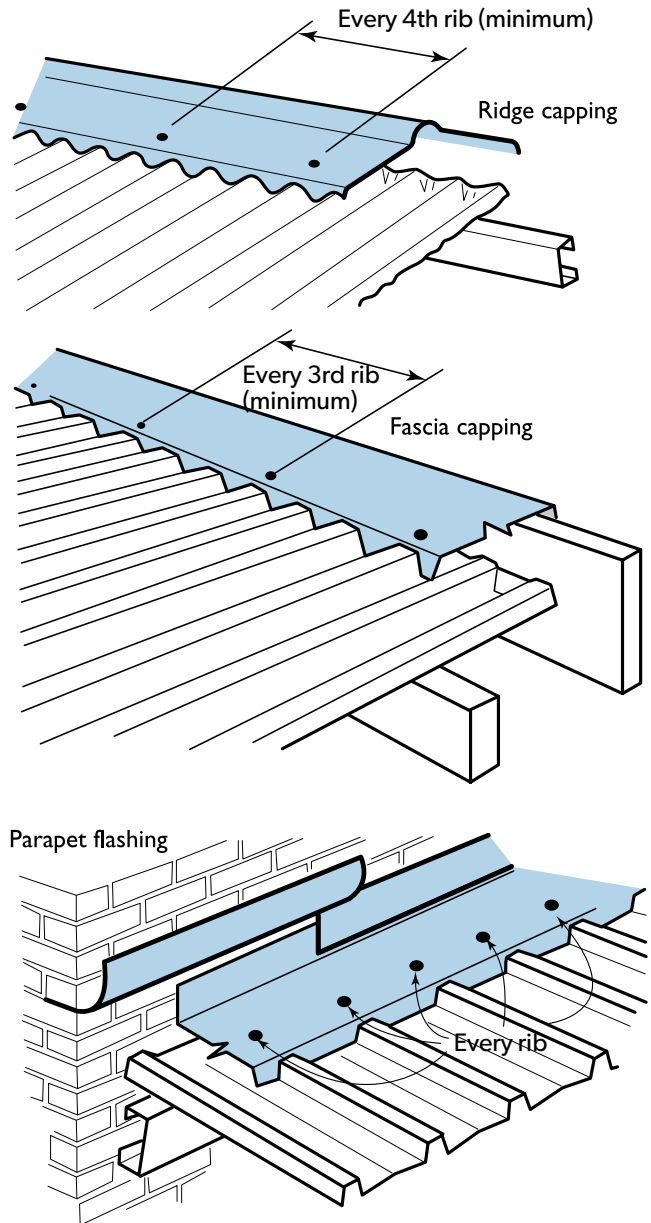
The above fastener spacing relates to the stitching of flashings to sheeting. It does not constitute the minimum number of fasteners required to fix the sheeting to purlins.

#### Notching tools

Hand-operated notching tools cut one notch at a time. Each tool matches only one cladding profile. There are two types of tool; their use depends on whether or not the edge of the flashing has first been bent down.

**Table 3.6.1**  
Notching tools

Type of tool	Edge turned down before notching	Available for
Horizontal notching tools	No	Availability subject to inquiry KLIP-LOK 406
Vertical notching tools (also called speed notchers)	Yes	KLIP-LOK 700 HI-STRENGTH KLIP-LOK CLASSIC 700 SPANDEK, TRIMDEK Others subject to inquiry.



**Figure 3.6.1**  
Typical transverse flashings



Flashings provide the essential weatherproofing at the edges, and they sharpen the image of the finished job.

### 3.7 Using notching tools

After the cladding is fixed and the turn-ups finished, proceed as follows.

- Place a flashing with the notch-edge resting on the ribs.
- Locate your notching tool over a rib with the notching head against the flashing.
  - VERTICAL TOOL: The body locates along the rib.
  - HORIZONTAL TOOL: the lugs on the underside locates on top of the rib.
- Raise the handle to open the tool and:
  - VERTICAL TOOL: lift the flashing into the mouth of the tool;
  - HORIZONTAL TOOL: slide the mouth of the tool over the edge of the flashing as far as it will go.
- Push down on the handle to perform the notching.
- Repeat for all ribs, checking in each case that the flashing is correctly positioned.
- If you are using a horizontal tool, bend down the tongues between the notches over a suitable straight edge (such as a piece of timber).

#### Notching with tinsnips

If notching tools are not available, flashings can be notched to the rib profile with tinsnips (Figure 3.7.2). The procedure is sometimes known as scribing. After the cladding is fixed and the turn-ups finished, proceed as follows.

- Place the flashing with the turned-down edge resting on the ribs.
- Mark out the notching using a template positioned over each rib.
- Cut the notches with tinsnips.

This procedure is also used for hip cappings.

#### Fasteners for transverse flashings

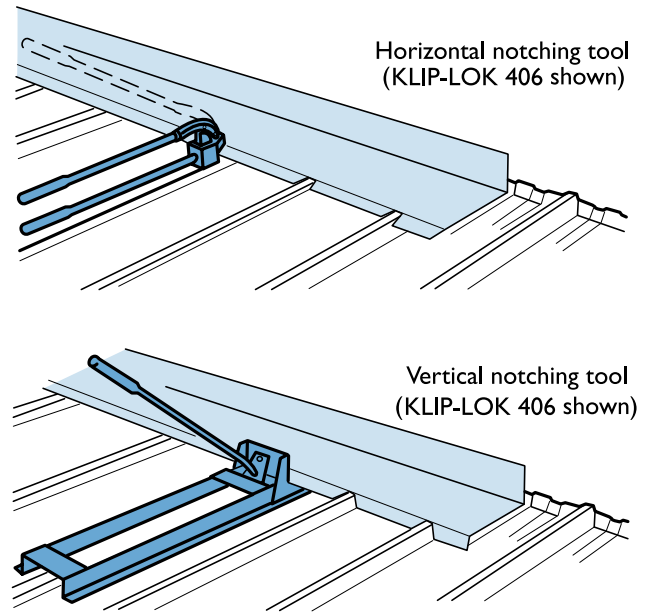
You must properly fix both flashings and the ends of all sheets.

Where the cladding is pierce-fixed through crests, and the position of the purlin allows it, the fasteners used to fix the sheets, may also fix the flashings.

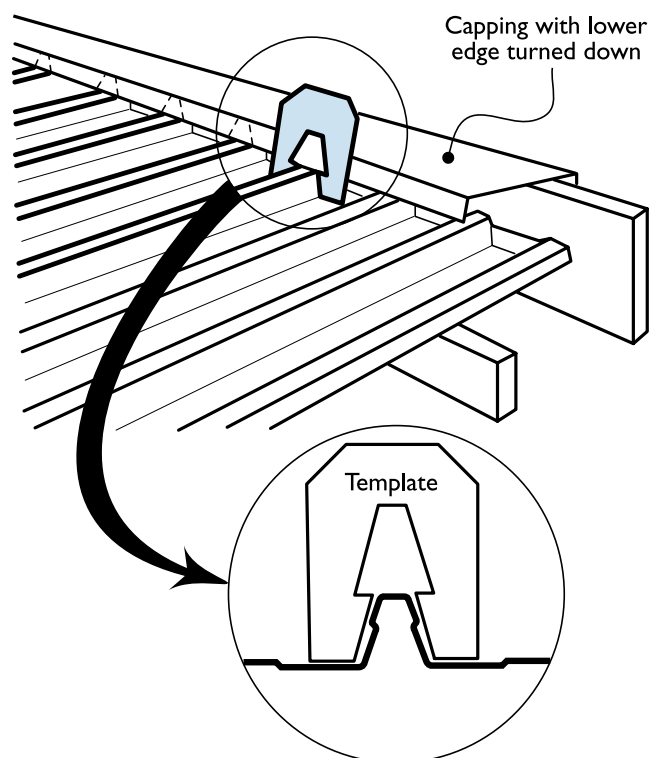
On all other installations, pierce-fix your flashing to the ribs or crests of the sheets.

#### Joining flashings

The overlaps of transverse flashings should be sealed with a recommended sealant and fastened. Before finally positioning and fixing the lap, turn over the top piece and apply a 3mm bead of sealant across the flashing, about 12mm from the end.

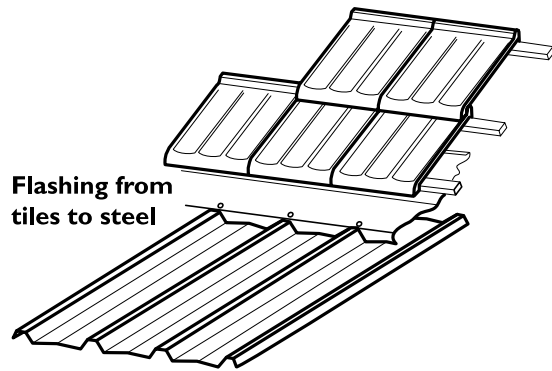
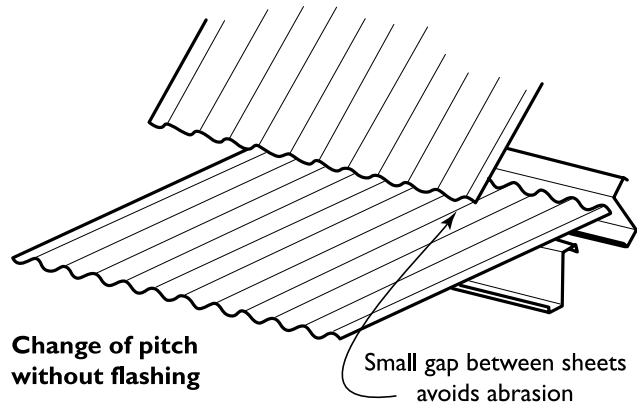
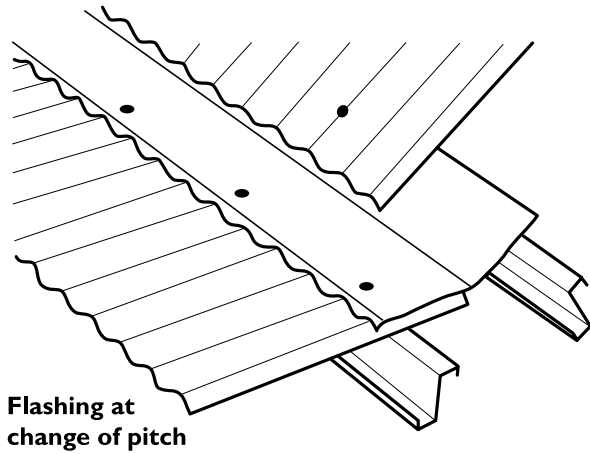


**Figure 3.7.1**  
Using notching tools



**Figure 3.7.2**  
Using a template to mark out for notching with tinsnips

### 3.8 Flashing at change of pitch



**Figure 3.8.1**

Typical flashing at changes of pitch

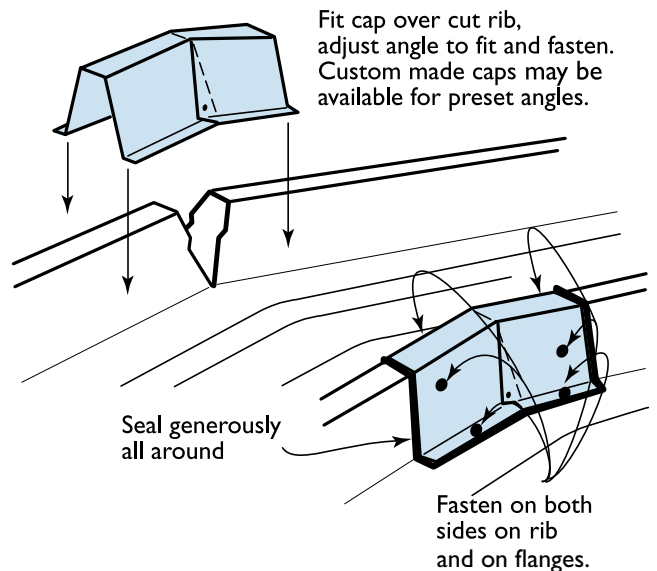
### 3.9 Capped bent ribbed roofs

Tray cladding can be used in continuous lengths from eave to eave by cutting the ribs and bending the pans at the ridgeline. The same process is used on Mansard roofs. Caps are fitted over the cut ribs, which open up when the pans are bent. Fitting the rib caps can be time-consuming and care must be taken with sealing to avoid any possibility of leakage.

The ribs must be cut squarely, with a metal cutting blade in a power saw, set to the depth of the rib minus 2mm.

In some states pressed steel caps may be available to suit KLIP-LOK ribs, though the range of angles is limited. Caps can be handmade to suit any angle from flat sheet.

KLIP-LOK is most frequently used for capped bent ribbed roofs, but LONGLINE 305, TRIMDEK or even SPANDEK can be used. For these four profiles the rib caps can be made from pieces of rib profile cut from a short length of cladding. A neutral-cure silicon sealant should be used.



**Figure 3.9.1**

Capped bent ribbed roof

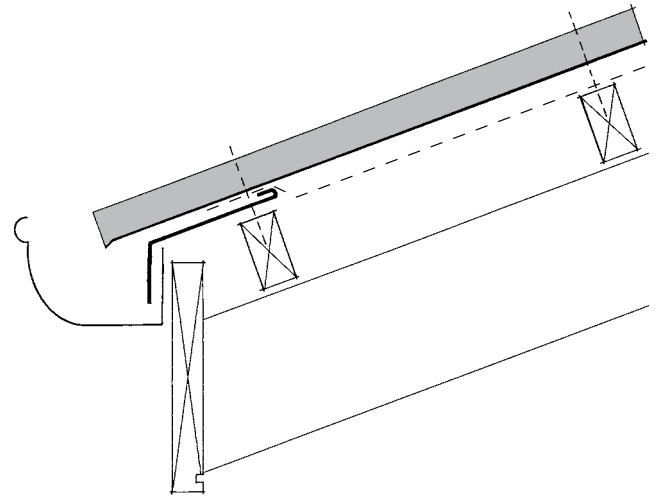
### 3.10 Gutter apron

Where the ends of roof cladding are exposed to environmental contaminants such (industrial pollutants, sea salt) provide an over flashing which discharges into the gutter. (see Figure 3.10.1 & 3.10.2)

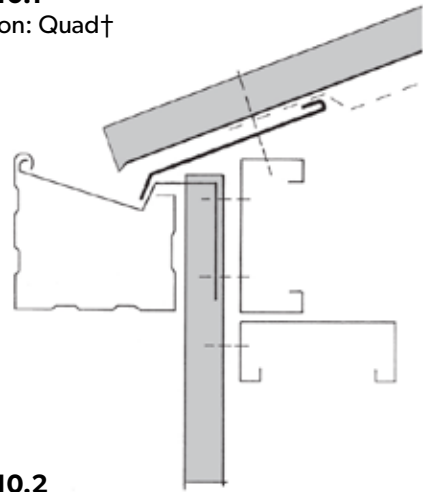
Benefits of gutter apron:

- Protects to the underside of the roof cladding/ underlay.
- Provides support for the roofing underlay which can be damaged by wind and solar radiation.
- There is an air gap between the spouting and the fascia where PVC spouting is used, caused by the thickness of brackets. In areas exposed to sea air, a gutter apron can minimise the risk of corrosion of the unwashed area.
- Can be used if there is no spouting or it has a low front.
- Protection against wind-blown embers.
- Contaminants can be driven up the ribs of the cladding if exposed in a severe environment. Metal flashings or profiled foam fillers can be used to prevent or reduce this.

The over flashing should extend 50mm into the gutter and the underlay finishes on the down-side of the flashing. Extend the underlay into the gutter by a minimum of 20mm if there is no over flashing into the gutter.



**Figure 3.10.1**  
Gutter apron: Quad†



**Figure 3.10.2**  
Gutter apron: TRIMLINE/SHEERLINE†

### 3.11 Types of penetration flashing design

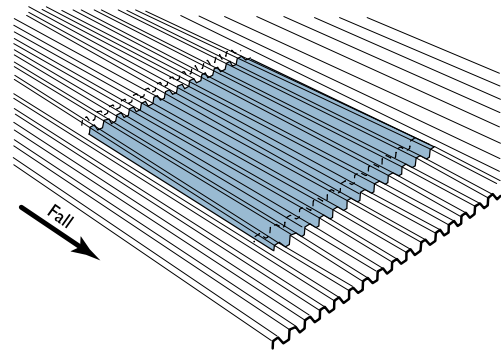
Penetration flashings can be divided into four different types.

#### Type A

Under flashings drain at the plane of the roof pan.

Soaker (under) flashings

- Suitable for any pitch;
- Most preferred detail;
- Curb side in line with the rib;
- Leave clearance of 10mm (minimum) all around;
- minimum of 100mm for all upstands;
- Drill holes for rivets before sealing;
- minimum 25mm for sealed laps;
- Order slightly longer cladding sheets to allow for lapping;



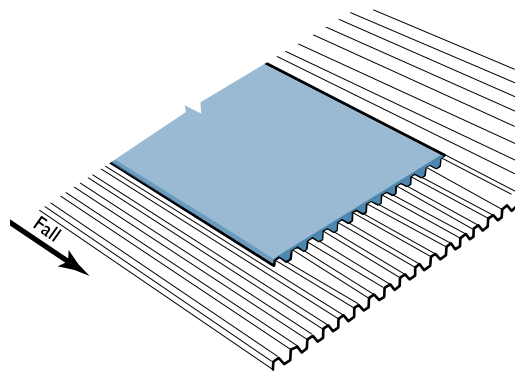
Type A Under soaker

#### Type B

Overflashings drain at the plane of the rib of the roof.

These are also known as back flashings.

- Simple to use
- Suitable for use to first purlin from the ridge if > 300mm wide.
- Not suitable for widths over 1.100m
- regarded as unattractive by some
- Suitable for use with sprung or over-roof design.



Type B Over watershed

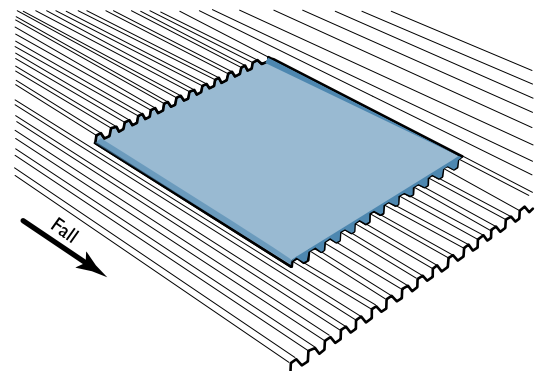
#### Type C

Tapered flashings that drain at the plane of the roof pan at the top, and over the ribs at the bottom.

Also known as transition or 'under/over' flashings.

Tapered or transition flashings

- Provides greater water run-off capacity
- Suitable for all roofs > 5°.
- Can be used for a retrofit
- Support required

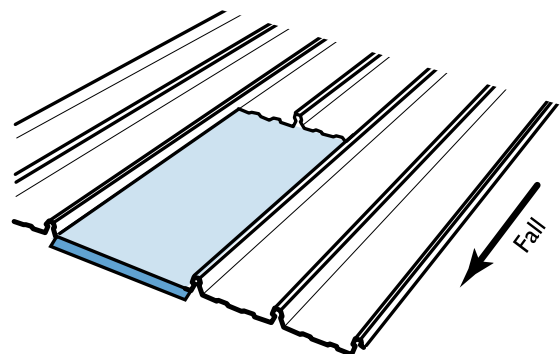


Type C Under/over tapered

#### Type D

Soaker flashings that drain at the plane of the roof pan at the gutter

- Simple
- Provides greater water run-off capacity
- Suitable for all roofs > 5°
- Can be used for a retrofit
- Support required
- Limited to 1.1m wide and 2.4m long



Type D Tray



### 3.12 Flashing large roof penetrations

Penetrations through ribbed cladding block the valleys (or pans), and thus affect the free flow of rainwater down a roof. All flashings have to weatherproof the cladding – but on the uphill side of large penetrations, they also have to channel rainwater sideways into valleys that run unobstructed to the eaves.

Four methods are described here. In all methods the ends of cut ribs may be closed off with caps on the outside of the rib, or with plugs inside the ribs. Plugs must be used on side-laps to allow the anti-capillary cavity to drain.

**Note: For masonry construction, Building Code Australia (BCA) requires the use of Damp Proof Course (DPC) to ensure weather-proofing. For acceptable methods see BCA section on weather-proofing masonry.**

#### Support framing

Wherever one or more of the sheet ribs are cut, you must provide framing to support the cut ends of the roof cladding each side of the penetration.

#### Existing flashing

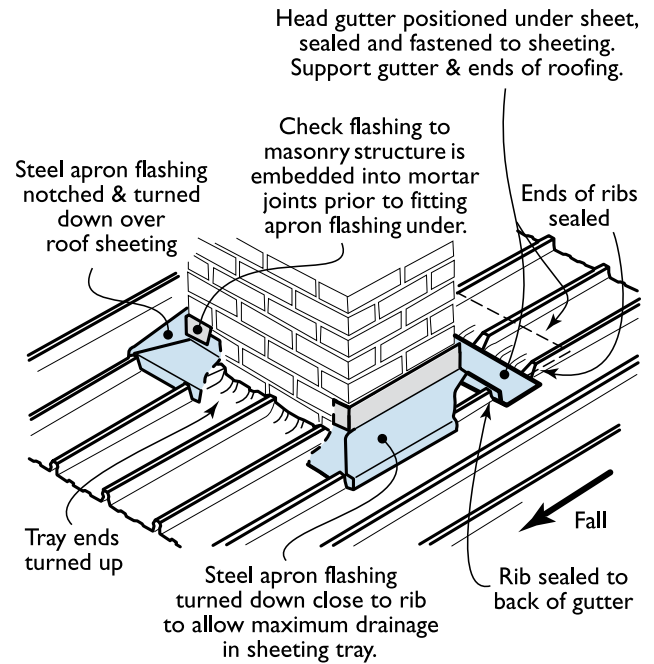
If you have to re-use lead flashings that are built into the structure, special protection is needed.

#### Method 1: Head gutter and apron flashings

This is often the simplest method, and commonly used for existing protrusions (Figure 3.12.1).

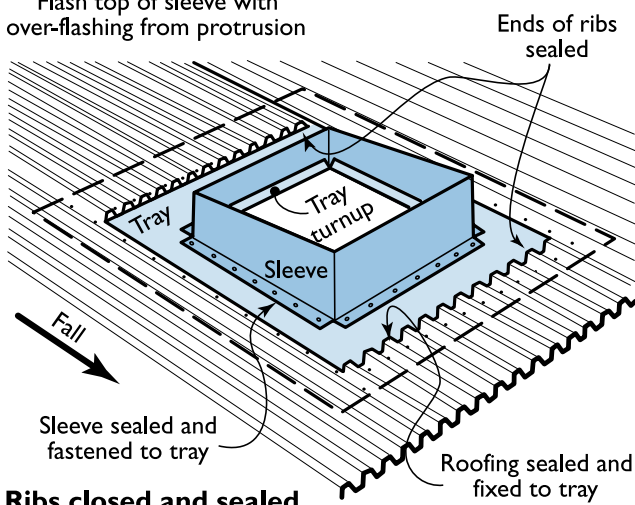
#### Method 2: Flat tray and sleeve

To avoid fitting and sealing end caps to all the sheet ribs on the low side of the penetration, an apron flashing can be fitted to the sleeve and sealed to the tray each side.



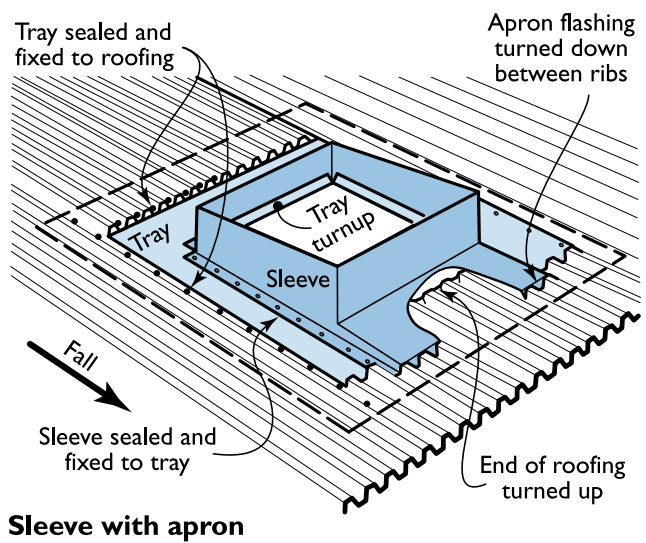
**Figure 3.12.1**  
Flashing method 1: Head gutter

Sleeve has clearance around protrusion.  
Flash top of sleeve with over-flashing from protrusion



**Ribs closed and sealed**

**Figure 3.12.2**  
Flashing method 2: Flat tray and sleeve

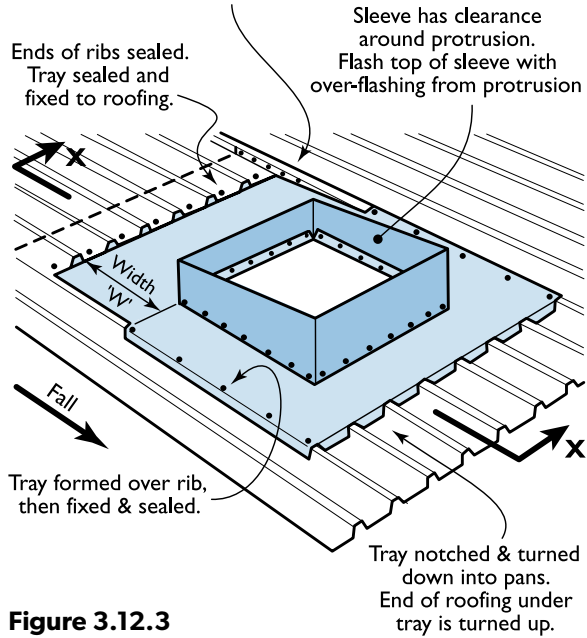


**Sleeve with apron**

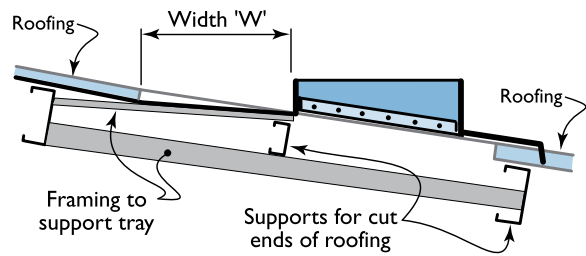
### Method 3: Tray gutter for steeper roofs

If the roof pitch is more than, say 1 in 12 (5°), you cut the roof cladding sufficiently high above the penetration to allow a tray gutter to raise rainwater over the top of the sheet ribs and divert it around the penetration (Figure 3.12.3).

Cut side of roofing rib to match slope of tray.  
Sides of tray turned up behind cut rib then sealed and fixed to rib.



**Figure 3.12.3**  
Flashing method 3:  
Tray gutter for steeper roofs



#### SECTION X-X

The base of the tray over width 'W' slopes slightly towards the protrusion. The width 'W' varies with this slope, the roof pitch and the rib height. Thus:

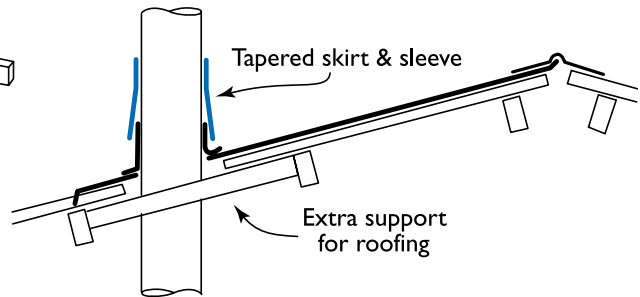
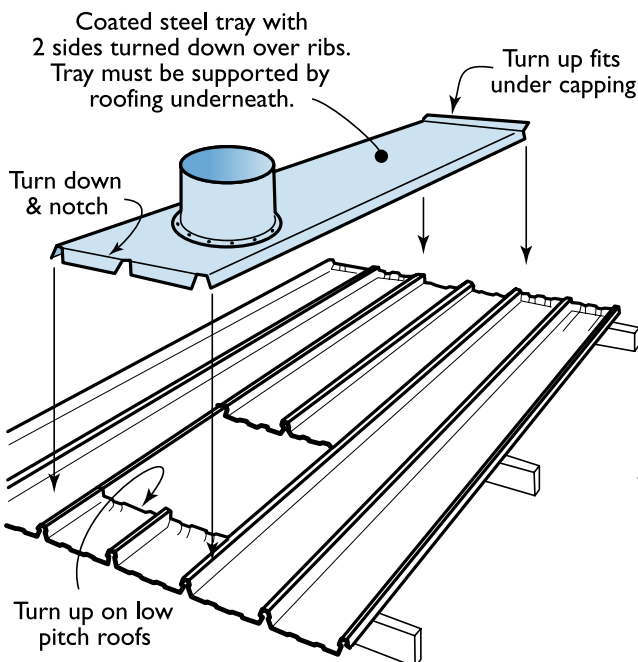
$$W = \frac{\text{Rib height}}{\sin(\text{roof pitch} - \text{slope of tray})}$$

For example: if the tray slopes 1 in 50 (1) and the roof pitch is 1 in 12 (5).

RIB DEPTH	WIDTH 'W' (minimum)
25 mm	360 mm
29 mm	420 mm
41 mm	590 mm

### Method 4: Penetration close to ridge capping

If a roof penetration is close to a ridge capping (or flashing above the penetration), you can fit a simple flat tray, on top of the roofing, so that it extends from under the capping down to a sleeve around the penetration.



**Figure 3.12.4**  
Flashing method 4:  
Penetrations close to ridge capping

### 3.13 Flashing small roof penetrations

A flanged cylindrical sleeve is a fairly simple method of flashing around small penetrations (such as pipe penetrations) which fit between the ribs of a roof sheet, or penetrate only a single rib.

Two methods are described here. Wherever roofing is cut, you must consider providing extra support for the roofing above and below the penetration. Where one or more of the sheet ribs are cut, you must provide framing to support at the cut ends of the roof cladding each side of the penetration.

#### Method 1: Tapered metal skirt and sleeve

This method uses parts custom-fabricated from metal. There is no positive seal between inside the building and the outside atmosphere (Figure 3.13.1).

#### Method 2: Sleeve

This is often the simplest method (Figure 3.13.2). Flexible flanged sleeves can be bought for flashing around penetrations of at least 350mm diameter. They overcome the problem of capping and sealing the open ends of cut ribs. A sleeve is commonly used, though silicone sealant has a wider operating temperature range and is available in a wider range of colours.

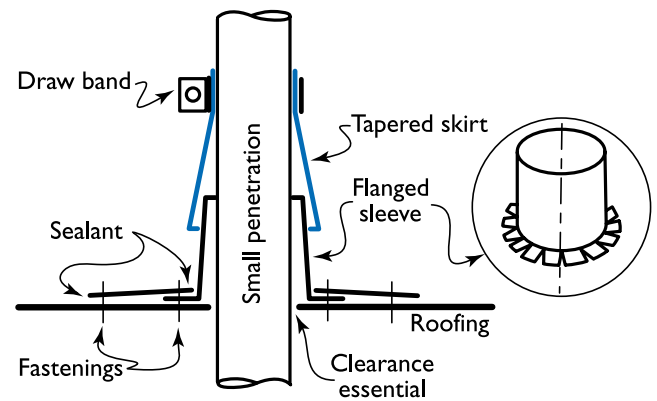
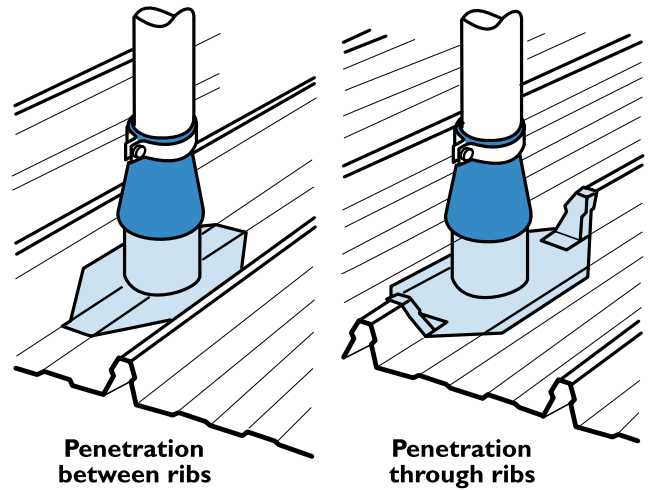
The flange around the base of the sleeve can be contoured by hand to match the cladding profile before it is sealed and fixed to the cladding.

Be careful not to dam any valleys or pans so that rainwater can drain freely from the high side of the roof penetration. Moisture held in such areas can cause deterioration of the sheet coating, reduced life expectancy or poor appearance.

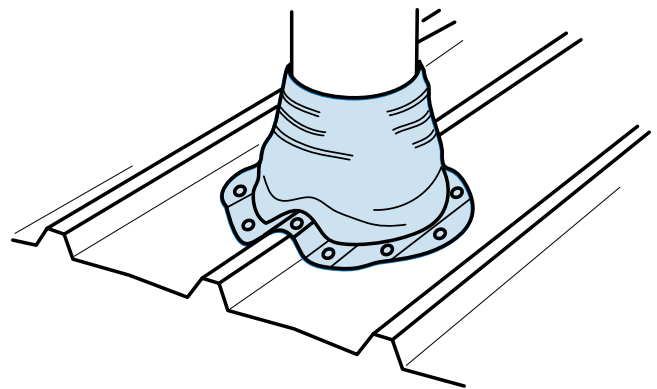
Where damming of any valley or tray is unavoidable, due to the size of the pipe penetration, treat the installation as a large penetration.

#### Copper penetrations

All copper pipe penetrations through ZINCALUME® or COLORBOND® steel cladding must be physically and electrically isolated from the cladding. This can be done by using a sleeve of PVC polyethylene or similar plastic that is also ultra-violet stable.



**Figure 3.13.1**  
Small penetration with metal skirt and sleeve



**Figure 3.13.2**  
Small penetration with sleeve  
(Dektite® sleeve illustrated)

### 3.14 Expansion

#### Background on thermal expansion

All metals expand and contract with changes in temperature. Although steel is by far the least affected of all the metals commonly used for roof and wall cladding, the changes in length experienced in very long runs of roofing are significant.

On a clear hot summer day, with no wind, the steel temperature in roof cladding can reach approximately 50°C in COLORBOND® SURFMIST®, 60°C in plain ZINCALUME® and more than 80°C in COLORBOND® NIGHT SKY®.

Examples of the thermal changes in lengths of steel cladding that would result from various temperature changes in the steel are shown in Table 3.14.1.

The actual expansion or contraction between the end of a sheet and the last support would only be a fraction of the figures shown because the movement in the length of fixed cladding would normally take place from the centre towards each end of the sheet. The movement at each end is thus only half the total expansion or contraction.

Transverse thermal expansion poses no problems in ribbed cladding because each rib absorbs some transverse movement.

#### Expansion joints

Thermal expansion effects are mitigated by slight bending of fastener shanks, thermal movement of the building structure, and slight flexing of the purlins (where they are not restrained by cleats or bridging). However, for very long runs of roofing, you should include an expansion joint to overcome linear thermal expansion.

Table 3.14.2 shows the maximum distance between the top and bottom rows of fasteners on a pierce-fixed sheet. For LONGLINE in distances of greater than 35m, please contact your Lysaght branch for advice. If the total length of two sheets pierce-fixed through the lap, or a single sheet exceeds this distance, then an expansion joint is needed. There should be no more than one pierce-fixed end-lap between expansion joints.

An expansion joint involves overlapping the ends of the upper sheets over the ends of the lower sheets—but with a clearance between them (about 15mm). A typical overlap is 250mm (this overlap is not the same as the overhang in Table 3.7.1 which does not apply to expansion joints). The clearance is usually created by having all the purlins for the roofing on the high side of the joint, higher than the roofing on the low side of the joint. An extra purlin is needed at the joint. A baffle flashing provides weatherproofing. See Figure 3.14.1.

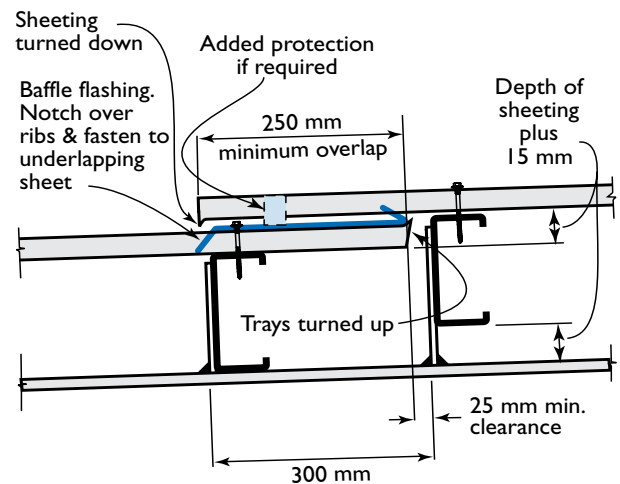
Where there is a risk of high winds, or the ribs result in a large opening, you may need protection, such as extra flashing or the inclusion of closed-cell foam infill strips.

**Table 3.14.1**  
Thermal expansion and contraction of steel cladding

Sheet length (mm)	Expansion or contraction (mm)		
	10 C° change	50 C° change	75 C° change
5000	0.6	3	4.5
10000	1.2	6	9
15000	1.8	9	13.5
20000	2.4	12	18
25000	3	15	22.5
30000	3.6	18	27

**Table 3.14.2**  
Maximum distance between top & bottom rows of fasteners on a sheet, before expansion joint is needed

Fixing system	Maximum distance between top and bottom rows of fasteners (m)
Pierce-fixed through crests	24
Walling pierce-fixed in valleys/pans	15



**Figure 3.14.1**  
Expansion joint detail

### 3.15 Standard roof flashings

#### LYSAGHT Standard flashings by region

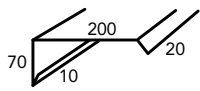
Although some flashings are common to all regions, the climactic conditions can cause variations in the local product requirements. Please check with your local Lysaght sales representative for the product offer in your area.

Other flashings are available as special orders.

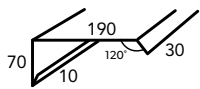
#### New South Wales

##### Barge capping

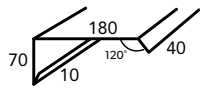
CUSTOM ORB, BLUE ORB & ACCENT 21



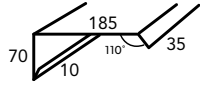
TRIMDEK & SPANDEK



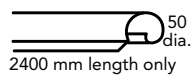
KLIPIK



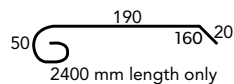
CUSTOM ORB ACCENT 35



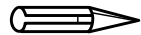
##### Barge roll



##### Barge roll capping



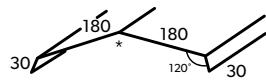
Spear point



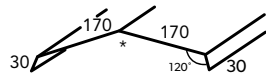
##### Ridge capping

\*Nominate roof pitch

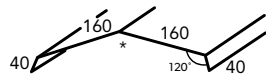
CUSTOM ORB, BLUE ORB & ACCENT 21



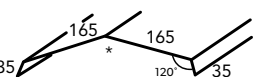
TRIMDEK & SPANDEK



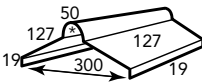
KLIPIK



CUSTOM ORB ACCENT 35

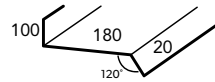


CUSTOM ORB, BLUE ORB & ACCENT 21

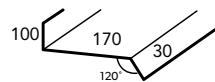


##### Apron flashing

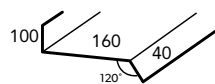
CUSTOM ORB, BLUE ORB & ACCENT 21



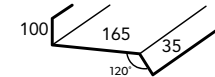
TRIMDEK & SPANDEK



KLIPIK & SPANRIB

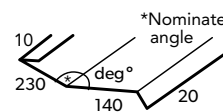


CUSTOM ORB ACCENT 35



##### Tile flashing

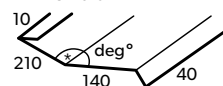
CUSTOM ORB, BLUE ORB & ACCENT 21



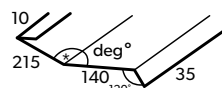
TRIMDEK & SPANDEK



KLIPIK & SPANRIB

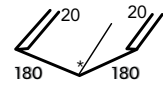


CUSTOM ORB ACCENT 35

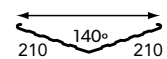


##### Valley flashing

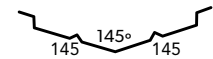
Valley flashing



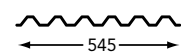
Ribbed valley



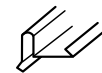
Structural valley



Valley support



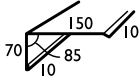
##### Barge gutter



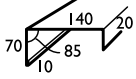
## Victoria

### Side capping

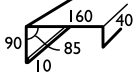
CUSTOM ORB (Universal capping)  
Code: UC



TRIMDEK & SPANDEK  
Code: STC



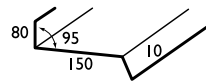
KLIP-LOK  
Code: BKC



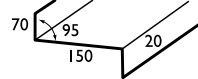
### Baffle flashing

(Parapet upstand side flashing)

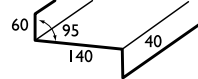
CUSTOM ORB (Universal)  
Code: UBF



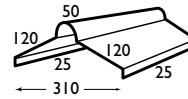
TRIMDEK & SPANDEK  
Code: STBF



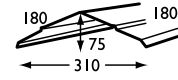
KLIP-LOK  
Code: BKBF



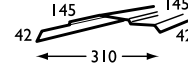
### Ridge capping



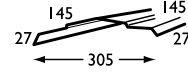
V-ridge



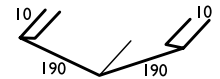
KLIP-LOK  
Code: BK



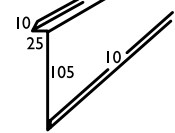
TRIMDEK & SPANDEK  
Code: ST



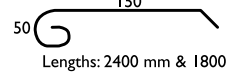
### Valley gutter



### Counter flashing



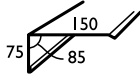
### Barge roll



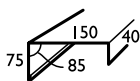
## Tasmania

### Barge capping

CUSTOM ORB, TRIMDEK & SPANDEK

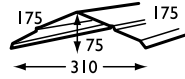


KLIP-LOK  
Barge capping

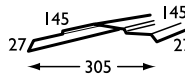


### Ridge capping

CUSTOM ORB  
V-top ridge capping

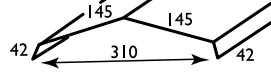


V-Top ridge capping

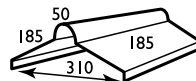


### Ridge capping

KLIP-LOK  
V-top ridge capping

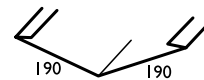


CUSTOM ORB & TRIMDEK  
Roll-top ridge capping extra scribing break



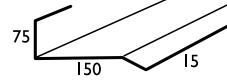
### Valley flashing

Valley gutter



### Miscellaneous flashing

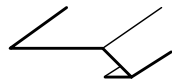
Under flashing



## Queensland

### Single-sided ant capping

0.4 mm & 1800 mm long  
50 x 38 mm      150 x 30 mm  
75 x 38 mm      200 x 38 mm  
113 x 38 mm      225 x 38 mm



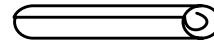
### Horizontal ant capping

0.4 x 50 x 1800 mm  
0.4 x 75 x 1800 mm



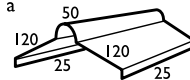
### Round vent stays

1800 mm long



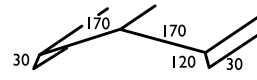
### Roll-top ridge capping

0.4 mm x 310 mm Custom cut to length  
Qth Qld have 450 mm girth roll top ridge  
(nd matching three break)



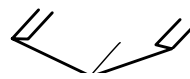
### Ridge capping - three break

CUSTOM ORB & TRIMDEK  
Standard 20 pitch  
Custom cut up to 8000 mm  
0.4 mm x 400  
0.55 x 400



### Valley gutter - three break

Custom cut up to 1800 mm  
0.4 x 400 mm  
0.55 x 400 mm



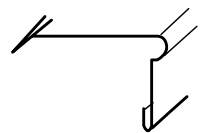
### Tile valley gutter

0.35 mm x 465 x 2400 mm



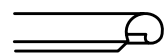
### Roll-top barge capping

0.4 x 400 Custom cut up to 8000 mm



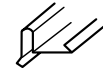
### Gable roll

0.55 x 50 x 1800 mm  
0.55 x 50 x 2400 mm



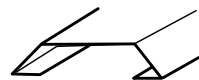
### Barge gutter

Code: BG



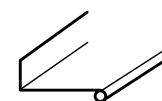
### Double-sided ant capping

0.4 mm & 1800 mm long  
38 x 117 x 38      38 x 200 x 38  
38 x 113 x 38      38 x 225 x 38  
38 x 150 x 38



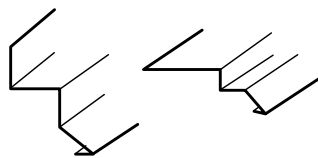
### Window flashings/ Door heads

1800 mm long  
50 x 38 mm  
75 x 38 mm W.S.  
113 x 75 mm Q.H.C.



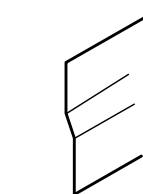
### Bribie Island ant capping

Vertical/horizontal ant capping  
0.4 x 50 x 1800 mm  
0.4 x 75 x 1800 mm



### Drip strip

0.4 mm x 50 x 1800 mm

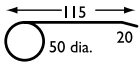


## Western Australia

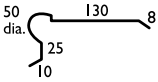
### Bargemould/corner capping

Custom cutting: 2-3 days

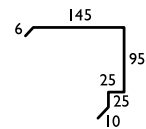
Type A edgeroll, 1800 mm long



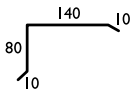
Type C edgeroll, up to 6000 mm long



Type E bargemould  
1800 & 2400 mm long & custom cut  
available

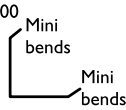


Type R bargemould  
1800 & 2400 mm long

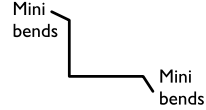


### Corner flashings

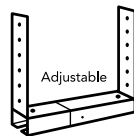
All custom cut  
External Mini bends  
75 x 75  
100 x 100



Internal  
150 x 100  
150 x 150



### Adjustable box gutter brackets



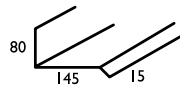
Size 1: 250-400 mm  
Size 2: 400-650 mm  
Size 3: 700-1000 mm

### Spandek gutter boards

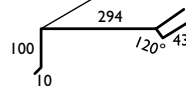
550 or 770mm wide

### Barge capping & parapet flashing

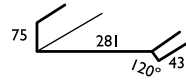
All custom cut  
CUSTOM ORB & SPANDEK



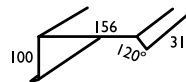
KLIP-LOK Barge



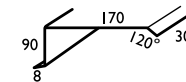
KLIP-LOK Parapet



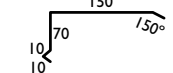
SPANDEK Barge



TRIMDEK Barge

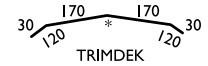


CUSTOM ORB Parapet



### Ridge capping

All custom cut



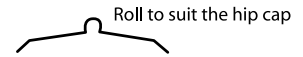
TRIMDEK

Code: RC2



CUSTOM ORB

395 mm girth



Suits up to 25 pitch. 395 mm girth available up to 8000 long. Other widths (girths) available with max. length 4000.

### Roll ridge to suit fibreglass & plastic curving sections

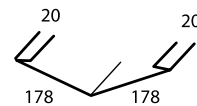
Material: 0.55 BMT



\* Nominate roof pitch

### Valley gutter

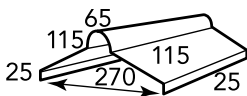
1800 & 2400 mm long  
0.4 mm BMT ZINCALUME or  
COLORBOND  
395 mm girth



## South Australia & Northern Territory

### Roll top ridge capping

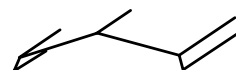
(Scribing break extra on nett price)  
300 mm girth  
350 mm girth



### Ridge capping

SPANDEK & TRIMDEK

KLIP-LOK

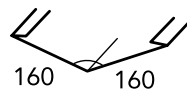


### Spandek gutter boards

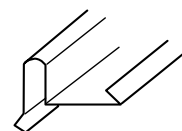


### Valley gutter

350 mm girth x continuous length  
400 mm girth x continuous length  
450 mm girth x continuous length



### Barge gutter

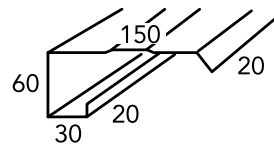


### Barge capping

CUSTOM ORB

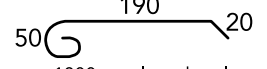
SPANDEK & TRIMDEK

KLIP-LOK



### Barge roll

190  
50  
1800 mm length only



### 3.16 Non standard roof flashings, cappings and gutters

This page shows some non-standard profiles. Please ask your local Lysaght branch for other options.

Girth range (mm)	
100	600
200	750
300	900
400	1000
500	1200

#### Preliminary

Check with your local Lysaght Service Centre for:

1. Available girth range
2. Available colours
3. Profiles not shown
4. Maximum lengths
5. Lead times
6. How to handle tapered flashings

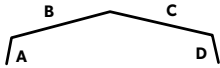
#### Order requirements

On a sketch show

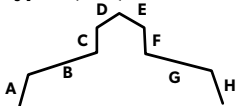
1. Profile type
2. Colour (or ZINCALUME® steel, or GALVABOND® if not COLORBOND® steel)
3. Side on which colour is to be (use letters shown below)
4. Dimensions (use letters shown below)
5. Angles on all bends that are not 90 degrees
6. Quantity and lengths

#### Profile types

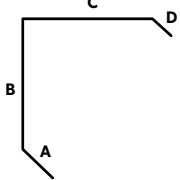
Type 1 (CF1)



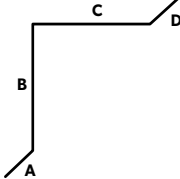
Type 2 (CF2)



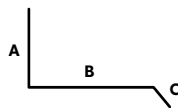
Type 3 (CF3)



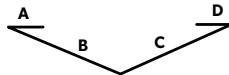
Type 4 (CF4)



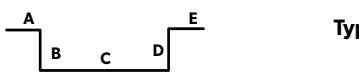
Type 5 (CF5)



Type 6 (CF11)



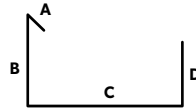
Type 7 (CF12)



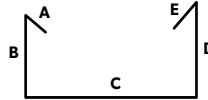
Type 8 (CF13)



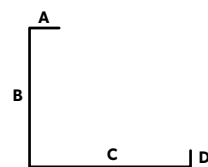
Type 9 (CF14)



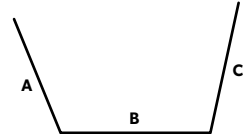
Type 10 (CF15)



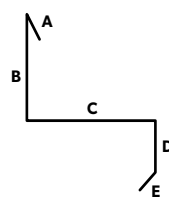
Type 11 (CF31)



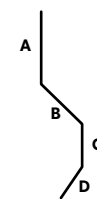
Type 12 (CF32)



Type 13 (CF33)



Type 14 (CF35)



#### Availability of materials

State	BMT (mm)	State	BMT (mm)
NSW	0.55 ZINCALUME, GALVABOND, COLORBOND 1.0, 1.2, 1.6 GALVABOND	Vic & Tas	0.55 ZINCALUME, GALVABOND, COLORBOND 0.80, 1.00 ZINCALUME, GALVABOND
WA	0.40, 0.55 ZINCALUME, COLORBOND 0.8, 1.0, 1.2 ZINCALUME, GALVABOND 1.6 GALVABOND	Qld	0.40 ZINCALUME, GALVABOND, COLORBOND (Up to 400mm girth) 0.55 ZINCALUME, GALVABOND, COLORBOND 1.0 ZINCALUME, GALVABOND 1.2, 1.6 GALVABOND 0.80 ZINCALUME
NT & SA	0.40, 0.55, 0.80, 1.00 ZINCALUME 0.55 COLORBOND 0.4, 0.55, 0.8, 1.0, 1.2, 1.6 GALVABOND		



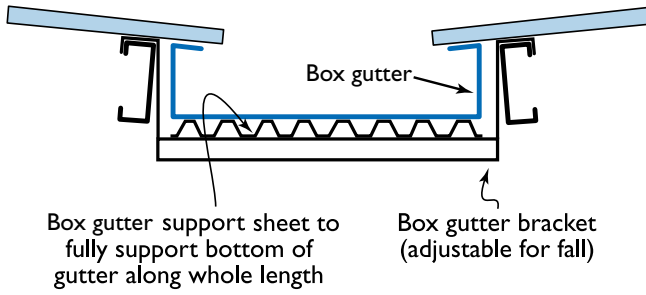
### 3.17 Box gutters

#### Lysaght standard design

Box gutters are designed to suit large water carrying capacity requirements, usually on commercial buildings.

In effect, a box gutter operates like an open drain. Designing for a box gutter requires adequate support for the gutter be provided, both at the sides and below, to provide for the anticipated weight of the water collected.

As with all gutters, adequate fall must be provided as well as a rainhead or other large capacity drainage system.

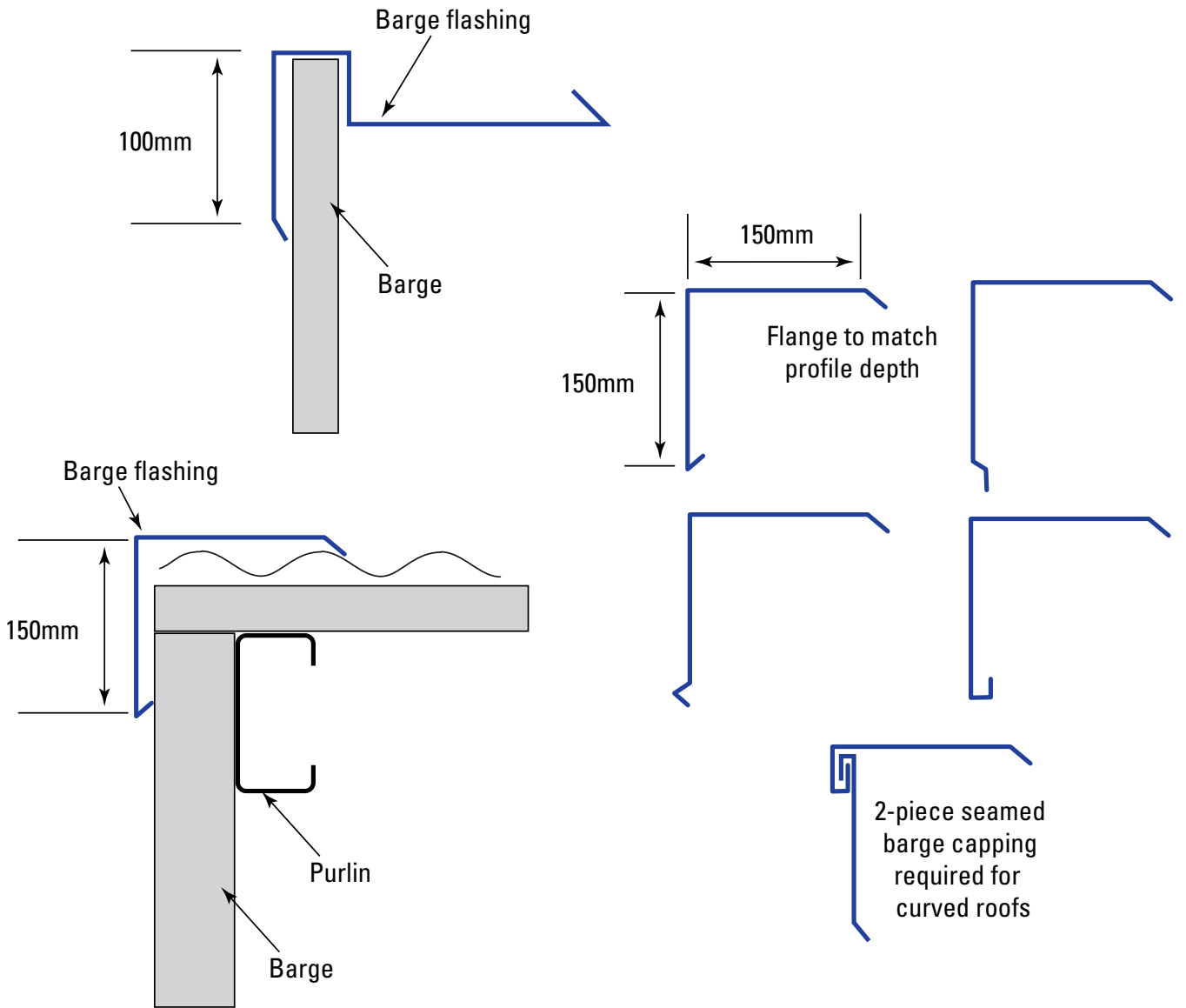


**Figure 3.17.1**  
Box gutter

### 3.18 Barge Gutters and cappings

Barge gutters are designed to provide an option for the rainwater carrying capacity for the sides of buildings.

This detail is the most common way to flash the side of a steel clad roof.



**Figure 3.18.1**  
Barge gutters and cappings

## 4. Typical wall flashings

### 4.1 Cladding orientation

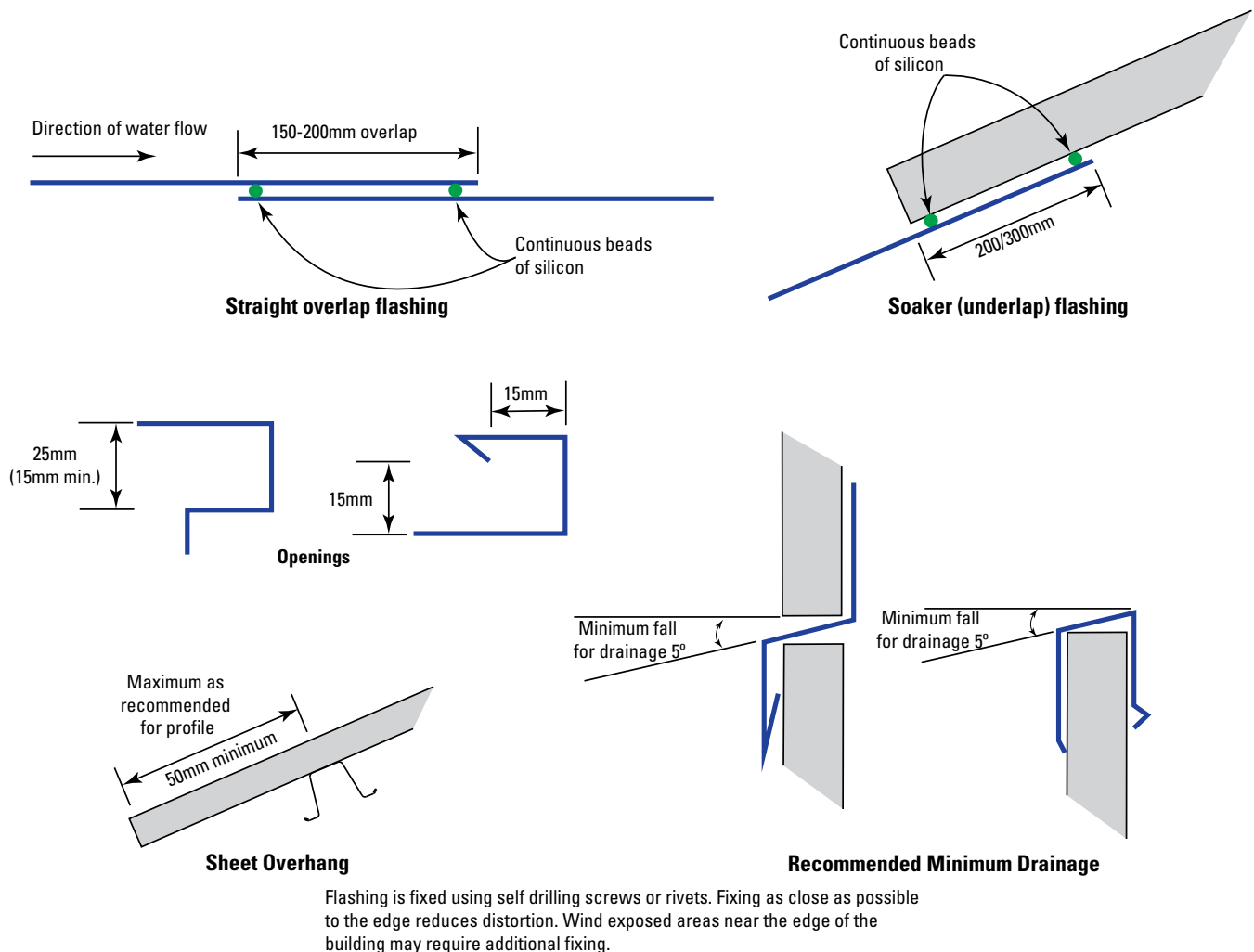
Cladding is usually installed with the profile running vertically or horizontally, though sheets have been laid diagonally—the choice is aesthetic.

Wind can drive rain hard against wall flashings, so it is important that you pay attention to the detailing of flashings around windows, doors, re-entrant and external corners, to ensure you get a watertight building. You also want a neat appearance.

We make wall flashings for some wall claddings (like EASYCLAD and MINI ORB) which are sometimes called trims. Where these are not suitable, custom-made flashings can be easily produced following the general principles described in this section.

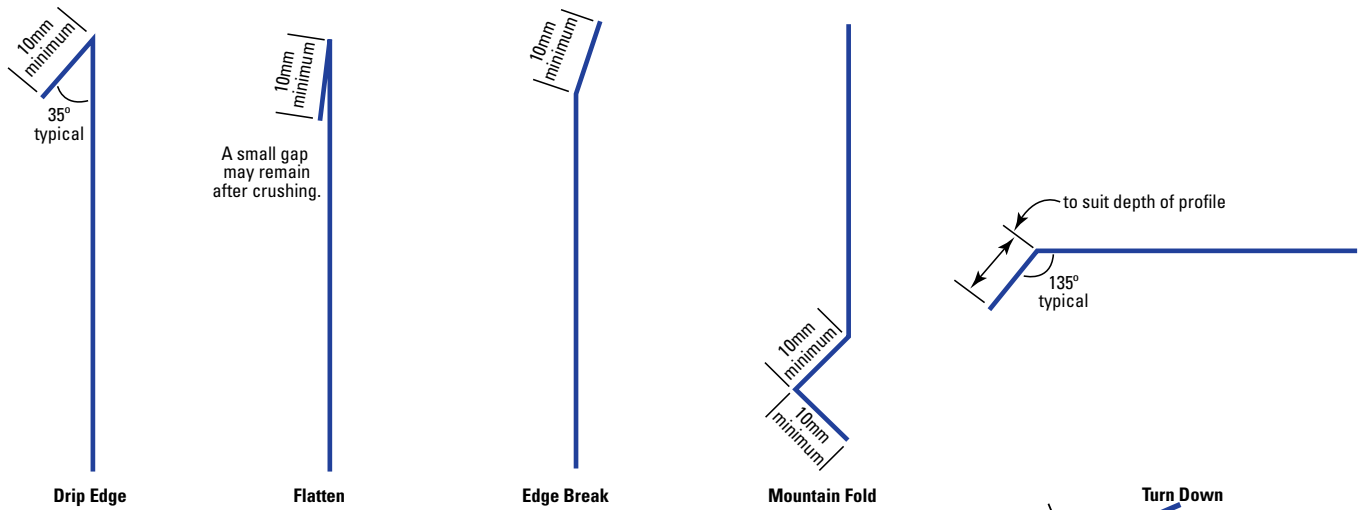
### 4.2 Walling profile running horizontally

- It is usual to lay the first sheet at the bottom of a wall and work upwards towards the eaves. You want the window and door flashings to fit properly into the valleys, so you should locate the first sheet relative to the heads and sills of doors and windows. Thus, you first have to decide where the cladding will eventually be located at the heads of doorways and at the heads and sills of windows before you place the first sheet.
- Where possible, select the vertical size of windows so that the flashings at both heads and sills will coincide neatly with the pitch of your profile
- Be sure that the crests of the profile align with each other on adjacent walls, either side of a corner—this ensures that horizontal flashings fit properly into all valleys.
- Where valleys create a void at flashings, use closed-cell foam plastic infill
- Where wind-driven rain can be expected, turn back the edges of flashing to restrict water movement past the flashing.

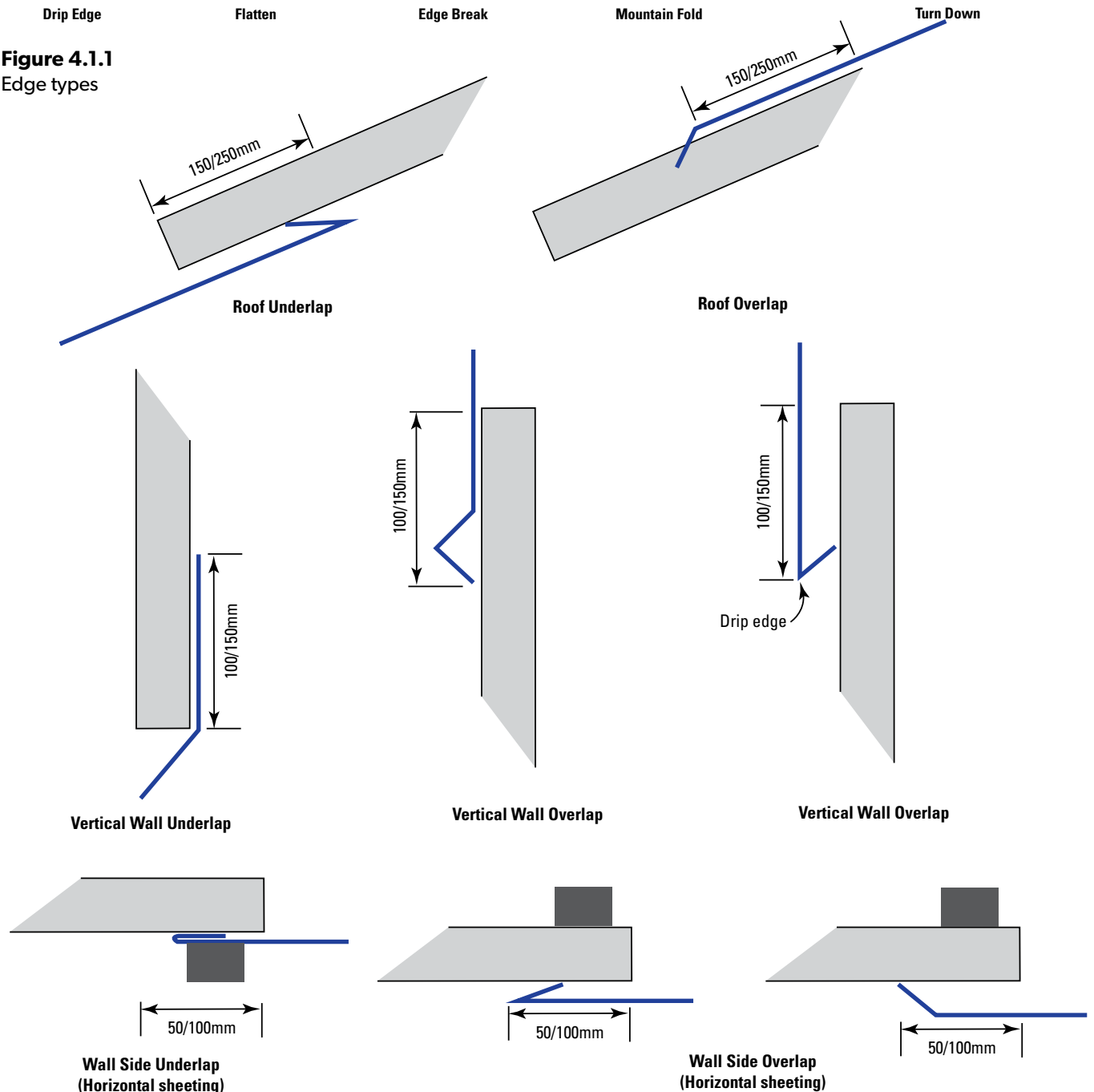


**Figure 4.1.1**  
Types of flashing laps

### 4.3 Types of flashings



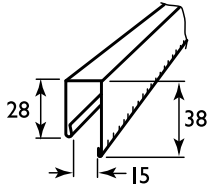
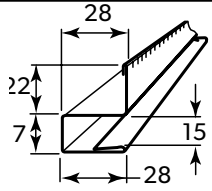
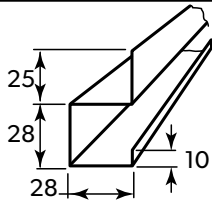
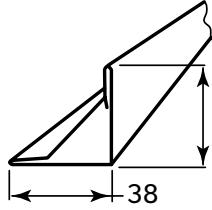
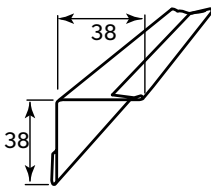
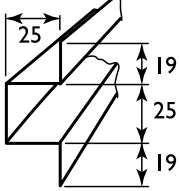
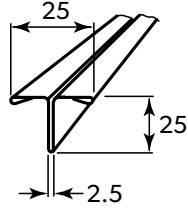
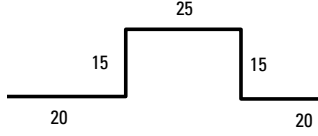
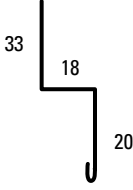
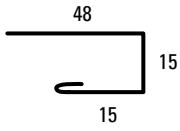
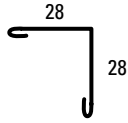
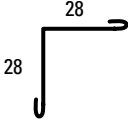
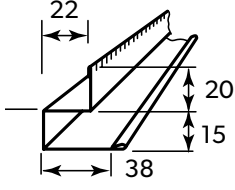
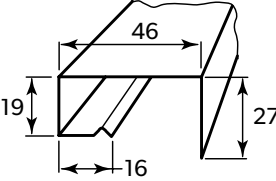
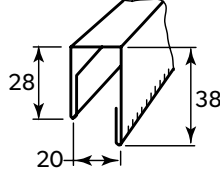
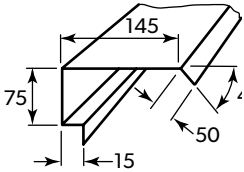
**Figure 4.1.1**  
Edge types



**Figure 4.1.3**  
Types of flashing laps

## 4.4 Optional wall trims

Available in ZINCALUME® steel or COLORBOND® steel\*

 <p>CD 1 Trim Channel Use with MULTICLAD, EASYCLAD</p>	 <p>CD 3 Fascia to Soffit Section, Use with PANELRIB, MINI ORB, EASYCLAD, MULTICLAD</p>	 <p>CD 4 Feature Section Soffit Use with PANELRIB, MINI ORB, EASYCLAD, MULTICLAD</p>	 <p>CD 5 External Corner. Use with PANELRIB, MULTICLAD EASYCLAD and MINI ORB.</p>
 <p>CD 6 Internal Corner. Use with PANELRIB, MULTICLAD EASYCLAD and MINI ORB.</p>	 <p>CD 8 Purlin hat Section Use with MULTICLAD, EASYCLAD</p>	 <p>CD 15 Tee Section. Use with PANELRIB, MULTICLAD EASYCLAD and MINI ORB.</p>	 <p>CD 20 Butt Joint trim - Top Hat. Use with PANELRIB, MULTICLAD and MINI ORB.</p>
 <p>CD 21 Butt Joint Trim - Overlap. Use with MULTICLAD</p>	 <p>CD 22 Edge Trim Use with MULTICLAD and MINI ORB. (Enquiry only in S.A.)</p>	 <p>CD 23 External Corner. Use with PANELRIB, MULTICLAD EASYCLAD and MINI ORB.</p>	 <p>CD 24 Internal Corner. Use with PANELRIB, MULTICLAD EASYCLAD and MINI ORB.</p>
 <p>CD 27 Fascia to Soffit Section. Use with PANELRIB, MULTICLAD, EASYCLAD and MINI ORB.</p>	 <p>CD 30 Fascia Capping. Use with PANELRIB, MULTICLAD, TRIMWALL, EASYCLAD and MINI ORB.</p>	 <p>CD 39 Trim Channel Use with EASYCLAD.</p>	 <p>EC 3 Fascia Capping. Use with PANELRIB, MULTICLAD, TRIMWALL, EASYCLAD and MINI ORB.</p>

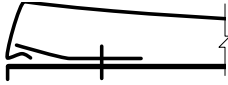
Our range of wall trims are available for the range of LYSAGHT cladding profiles to provide an attractive compliment to walls, ceilings or soffits.

Some trims are used to start the installation of the walling panels whilst others provide the perfect finishing touch.

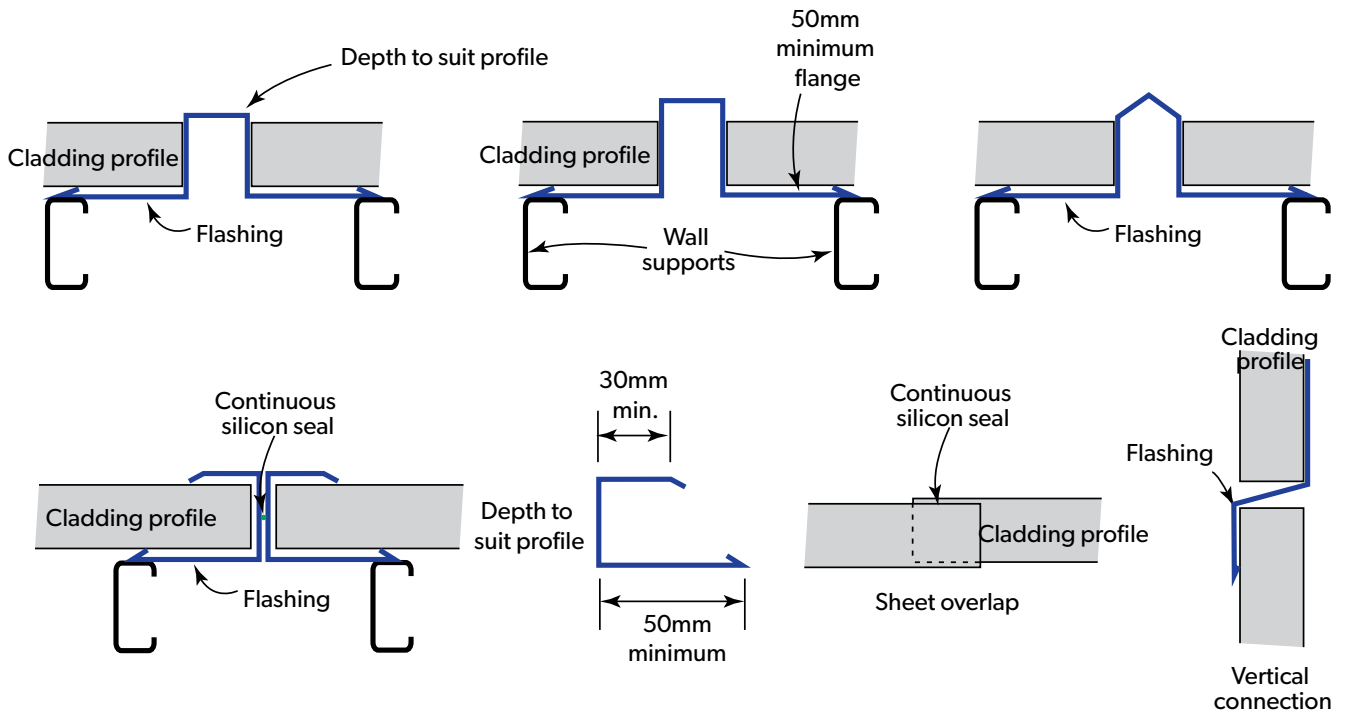
Made from COLORBOND® or ZINCALUME® steel\*, they are an attractive, long lasting addition to any walling installation.

Not all trims are available in all locations and some dimensions may vary from state to state - for local availability of wall trims, contact your local sales office.

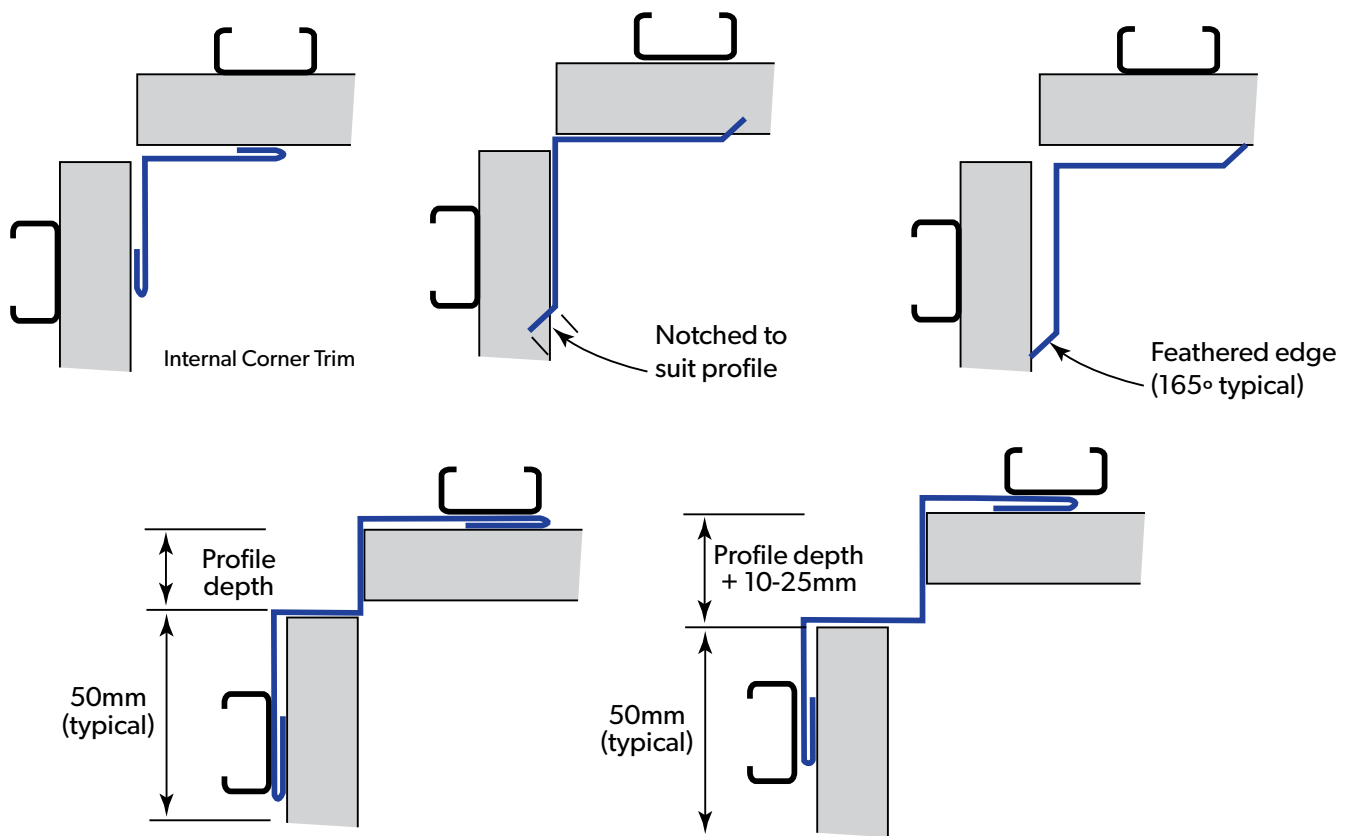
\*Other materials, such as stainless steel and COLORBOND® Ultra are available, subject to enquiry.

 <p>CD 40 Starter Clip Use with EASYCLAD.</p>
--

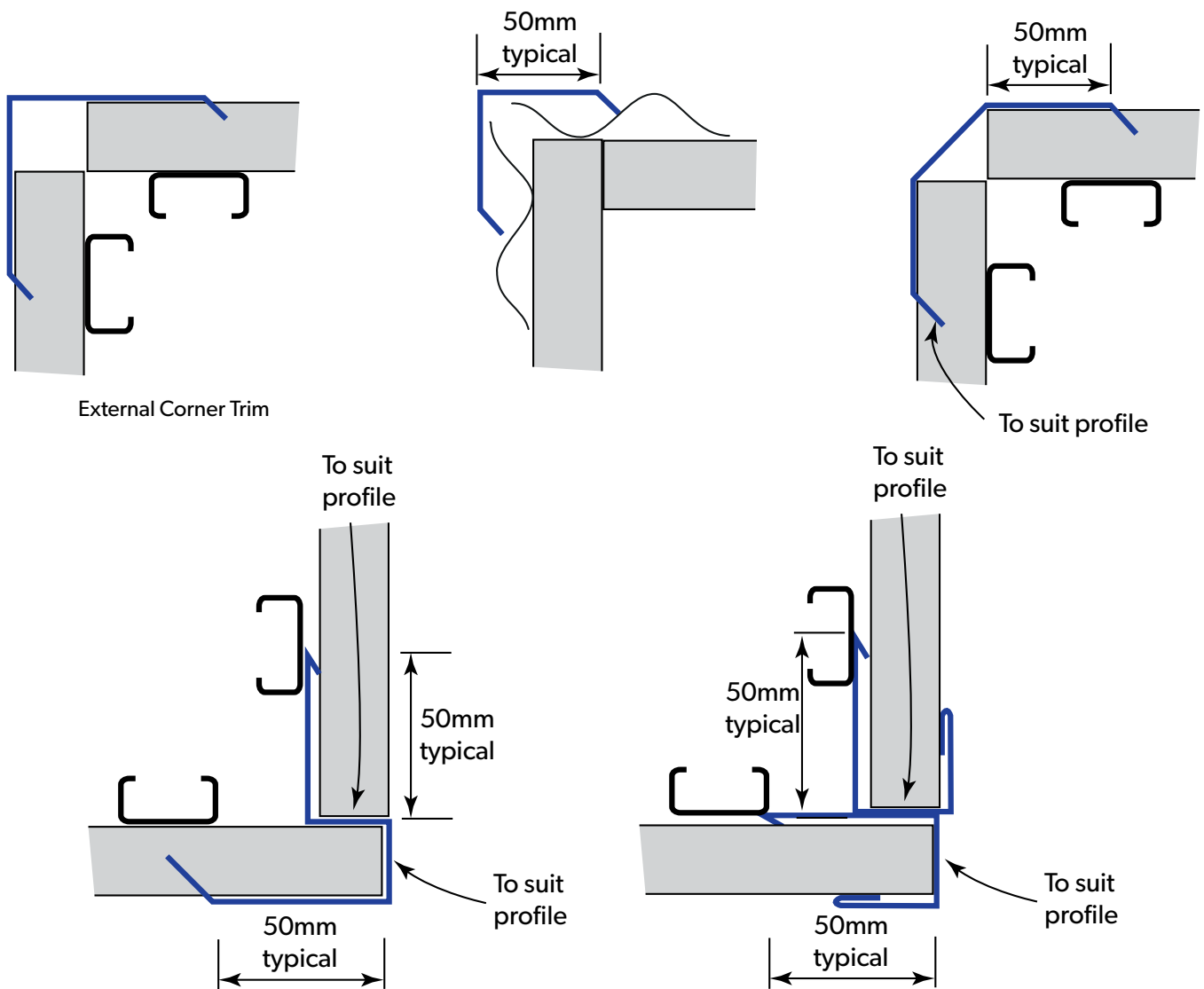
## 4.5 Mid wall connections



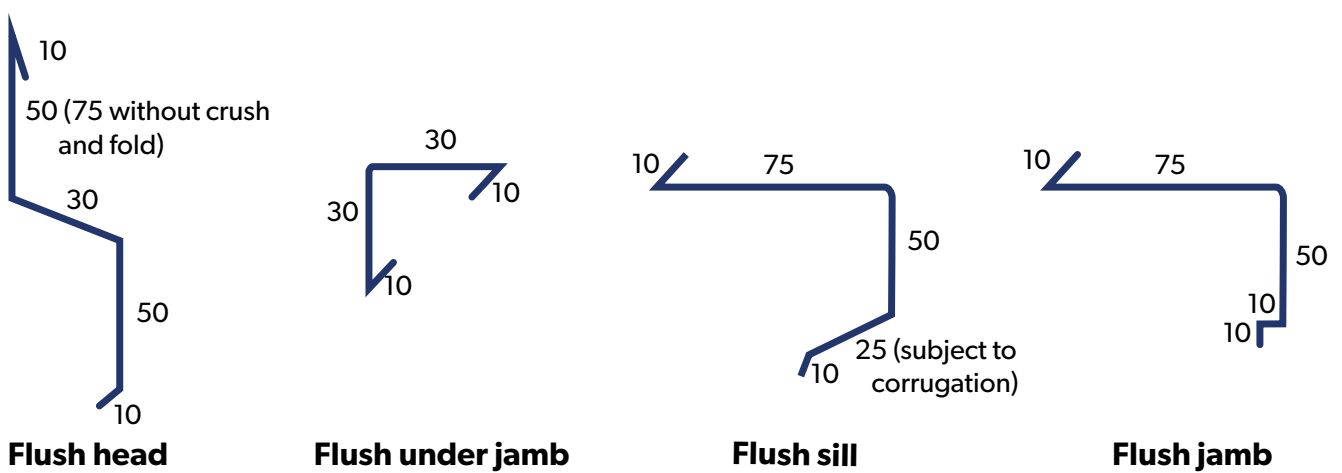
## 4.6 Internal wall connections



## 4.7 External corner connections



## 4.8 Flashing for horizontal cladding



### 4.9 Flashings for horizontal corrugate cladding

Extra care and attention to the detailing and fixing of horizontally oriented corrugate cladding is required. Designers using horizontally fixed corrugate sheets as a design feature should recognise that there are a number of requirements which differentiate horizontal from vertical profiled cladding.

Horizontal cladding exposes the defects in the visual appearance of the framing to a much greater extent than vertical cladding does. The plane of the supports both horizontally and vertically should be straight within a very limited tolerance (5mm in 10 metres) The vertical and horizontal planes of framing members should exhibit little or no twist. Therefore, the standard of framing should be inspected and approved the before the commencement of any cladding installation.

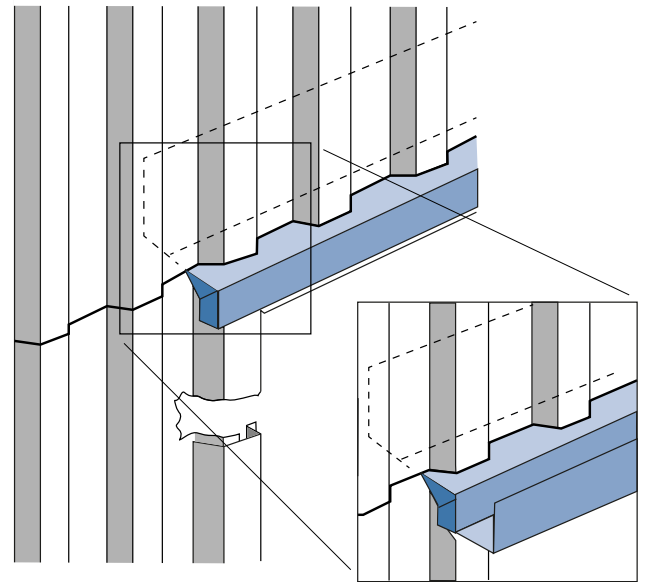
Horizontal cladding should be fixed in the pan as this provides a stronger, more economical and aesthetic fastening than crest or rib fixing. The wind design load for the building will determine the number, spacing and the position of the fasteners. A butt detail to join horizontal cladding which is simple and aesthetically pleasing is to provide a vertical break at structural steel frame centres. Use a top hat or tee flashing section at the joint, but ensure the exact sheet length required is used. These sheets must be cut accurately to within 1mm to provide a neat joint.

Condensation is likely when horizontal metal cladding is directly fixed to a lined or insulated wall. Therefore it is recommended that horizontal laps are sealed with sealant or lap tape.

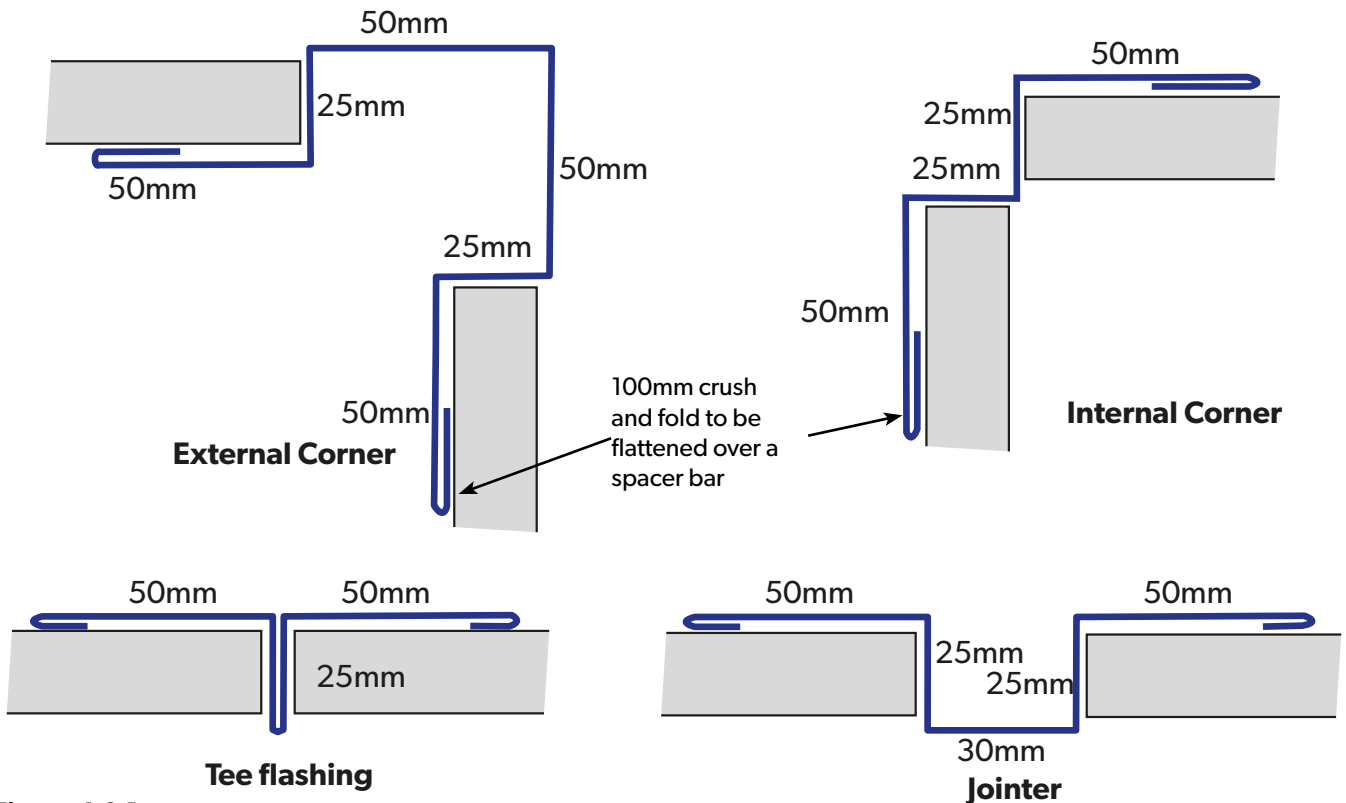
### 4.10 Flashings for vertical cladding

Detailing flashing for vertical cladding is similar to detailing roof cladding penetrations. This is because the water from the 'under' has to drain over at the window or door head. Automatic weathering is provided by a sheet lap at the head flashing. Either profile the vertical upstand of the head flashing or flatten the lap.

This detail can be used for corrugated, ribbed and trapezoidal cladding. Do not stop end the flashing but turn it down as per drawings 4.10.1 and 4.10.2



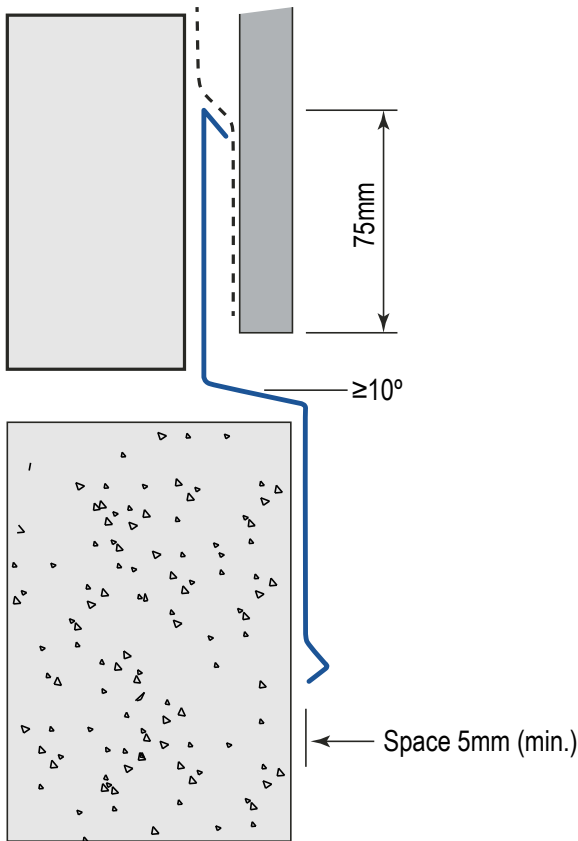
**Figure 4.10.1**  
Flashings for vertical cladding



**Figure 4.9.1**  
Butt details

 These drawings are based on drawings from the NZ METAL ROOF AND WALL CLADDING CODE OF PRACTICE (Version 2.2: 2012).

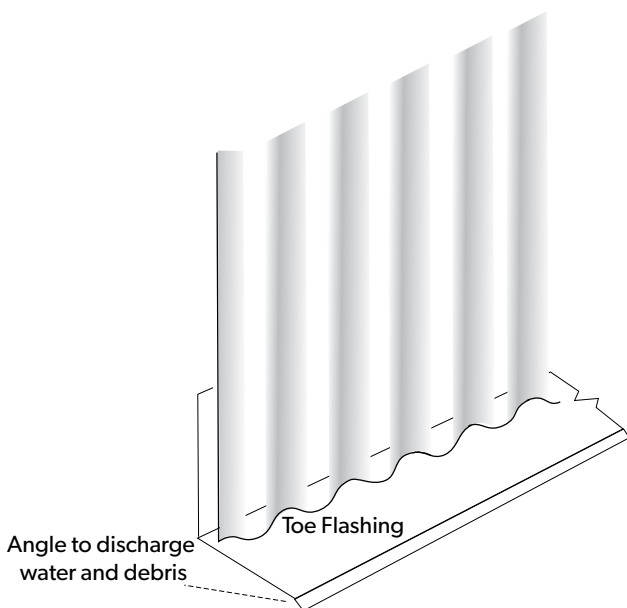




**Figure 4.10.2**  
Flashings for vertical cladding

### 4.11 Toe-mould type flashings

Flashing at wall footings should include a fall on “horizontal” planes & be of a sufficient size to ensure good drainage away from the sheeting & to avoid potential build-up of debris.



**Figure 4.10.3**  
Toe-Mould Type Flashing

### 4.12 Window flashing types

There are three types of window flashings:

- (a) flush mounted
- (b) recessed (or reveal)
- (c) butt

The module set-out of horizontal cladding should be determined by the height of the window.

Generally speaking, to achieve good weathering characteristics, window and door detailing should be performed after the cladding and other flashing has been fitted.

However, the installation of a head flashing, for example, requires that it is behind the cladding and protects the window by exiting over the cladding. The depth of the cladding determines the offset. A fall to the front of 10° (minimum) is recommended.

Lap the cladding at the window or door head height when lapping horizontal cladding.

If the window is within the depth of the wall of the building, the flashings are termed ‘reveal or recessed flashings’. Windows and doors can be recessed to the front of the frame or flush in line with the cladding. Either way, they both have the same overflashing design, however a recessed design has the advantage of a better weathering detail. A recessed design can result in unwashed areas of metal, which will require some maintenance for durability.

Because they do not overflash the metal cladding, butt flashing details are not considered suitable for residential closed cavity construction.

To avoid ponding and the build up of dirt and debris, all exposed horizontal metal flashings (including the head or sill flashings) must have a minimum 10° pitch.

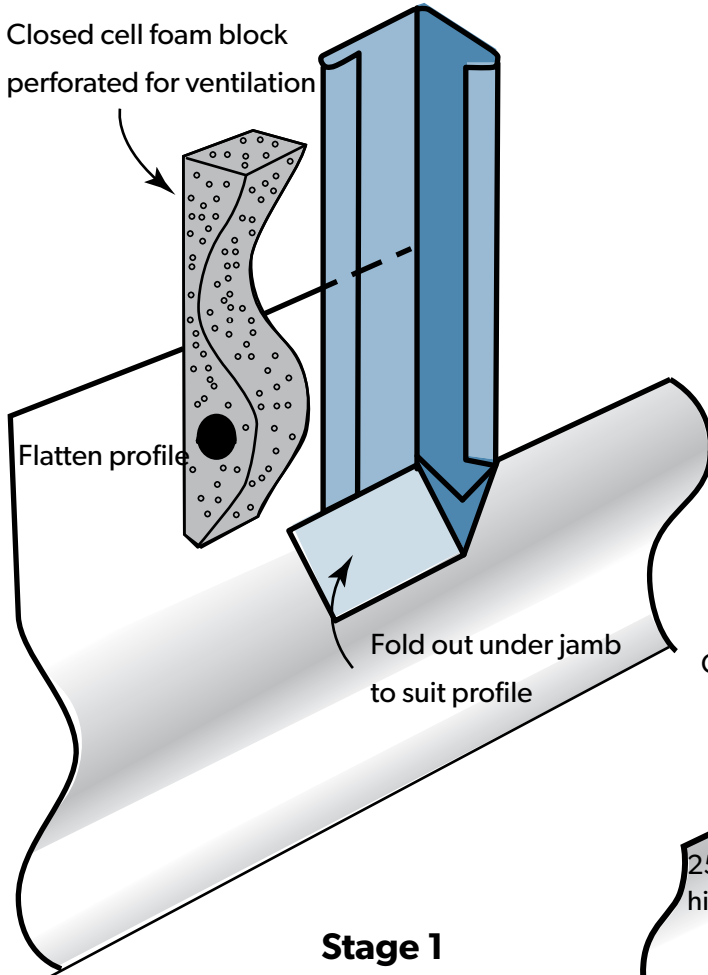
To provide a weather-tight joint, all sills should be riveted and sealed.

### 4.13 Window flashings for metal cladding

Metal clad buildings such as sheds and garages have generally been unlined and as such, the wall cavity is naturally vented. In such cases minor amounts of water penetration are acceptable. However, if the building is lined then greater moisture resistance is required. Cavity construction is required for lined and insulated buildings in higher risk areas for this reason. Buildings situated in a very high wind design load areas (<1.5.kPa.) and buildings that are two stories or more are considered to be higher risk.

The flashings that protect the sheets and any penetrations in horizontal cladding are the prime factor controlling weather-resistance. A cavity is required for all lined buildings because they are susceptible to the accumulation of condensation.

Some provision to remove condensation is required for all metal wall cladding. Condensation can occur when the humidity is high or when there is a large daily temperature differential. The frequency of condensation forming on the metal cladding will increase if the wall is insulated and the building is heated.



**Figure 4.13.1**  
Flush window flashings

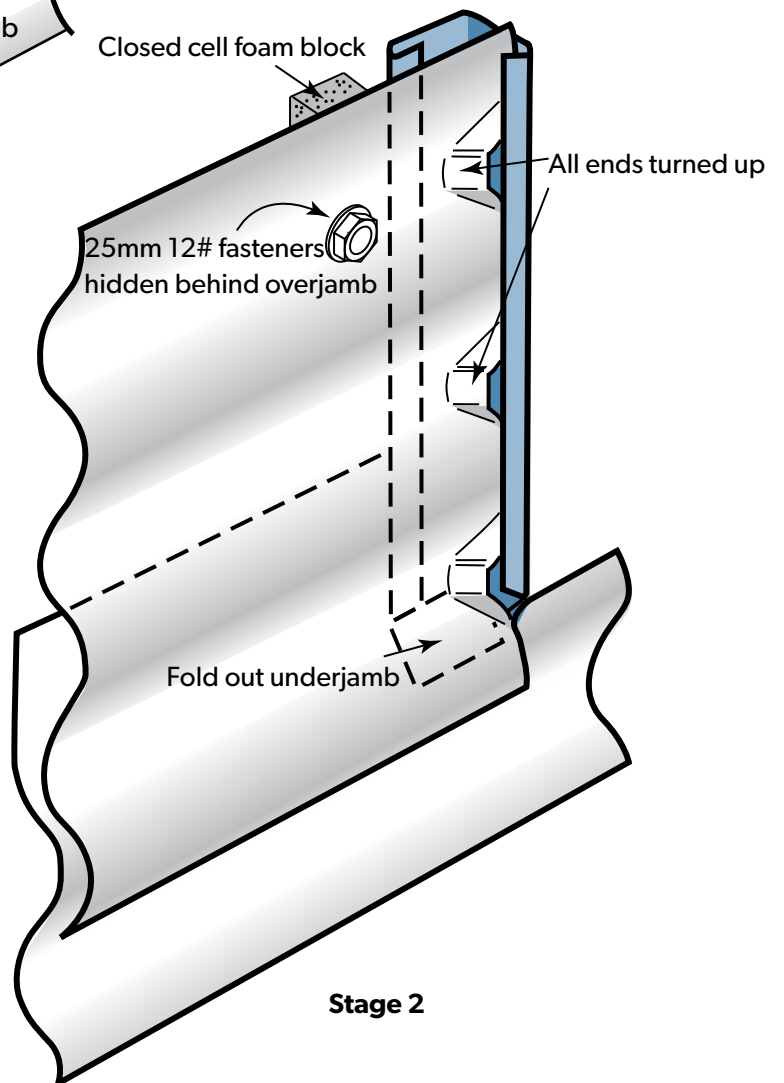
#### 4.14 Flush window flashings

The position of the profile rib may require the height of the sill flashing may have to be adjusted slightly.

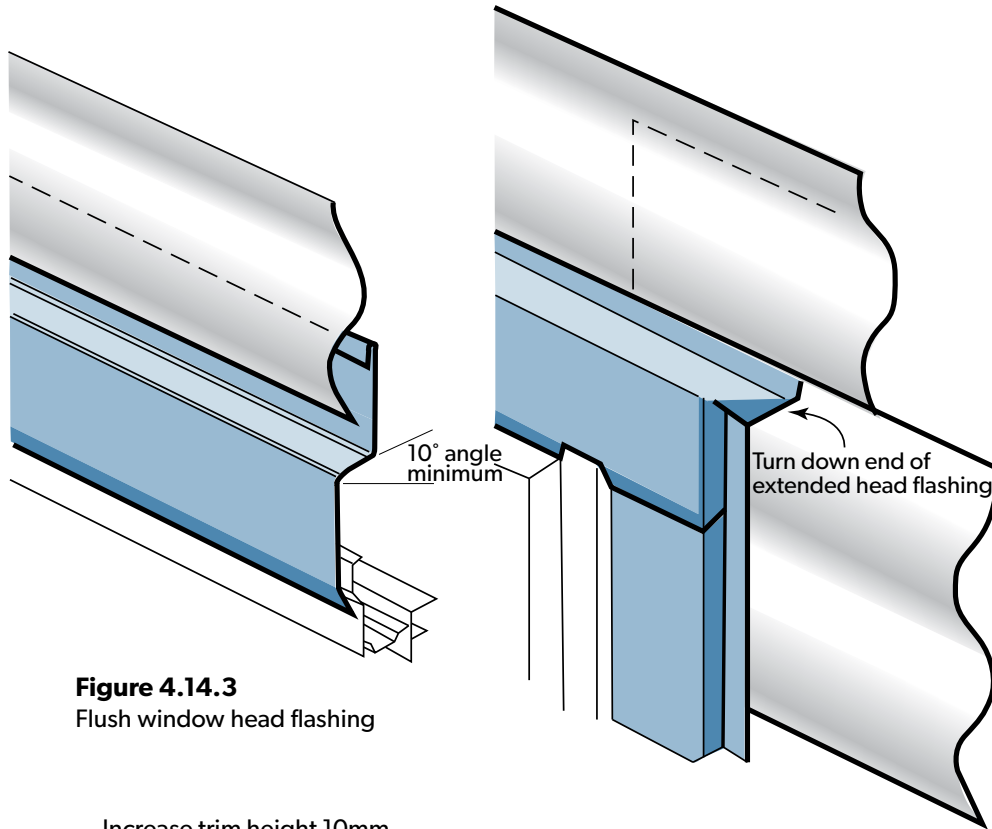
Flush mounted windows or doors permit a wide choice of flashings to be utilised. You can choose to have the window frame is mounted externally to the cladding, or timber facings, or any number of other designs.

An under jamb and a front or face jamb is used for both the flush and recess flashings.

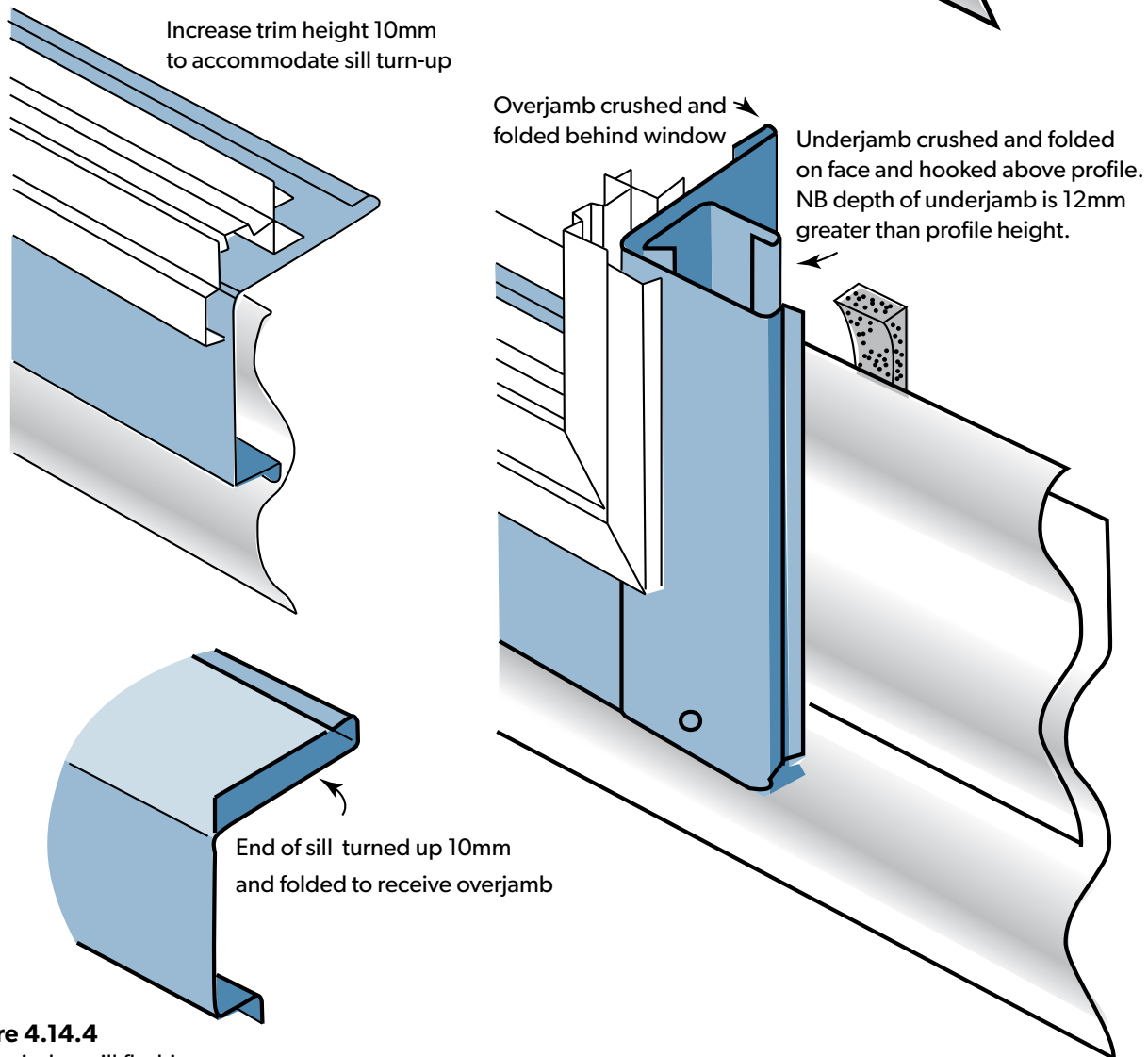
Add 10mm on the jamb liner size to the trim sizes for aluminium windows. Add 15mm vertically to the trim size for a flush flashing design as this allows for a 10mm packer.



**Figure 4.14.1**  
Flush window flashings



**Figure 4.14.3**  
Flush window head flashing

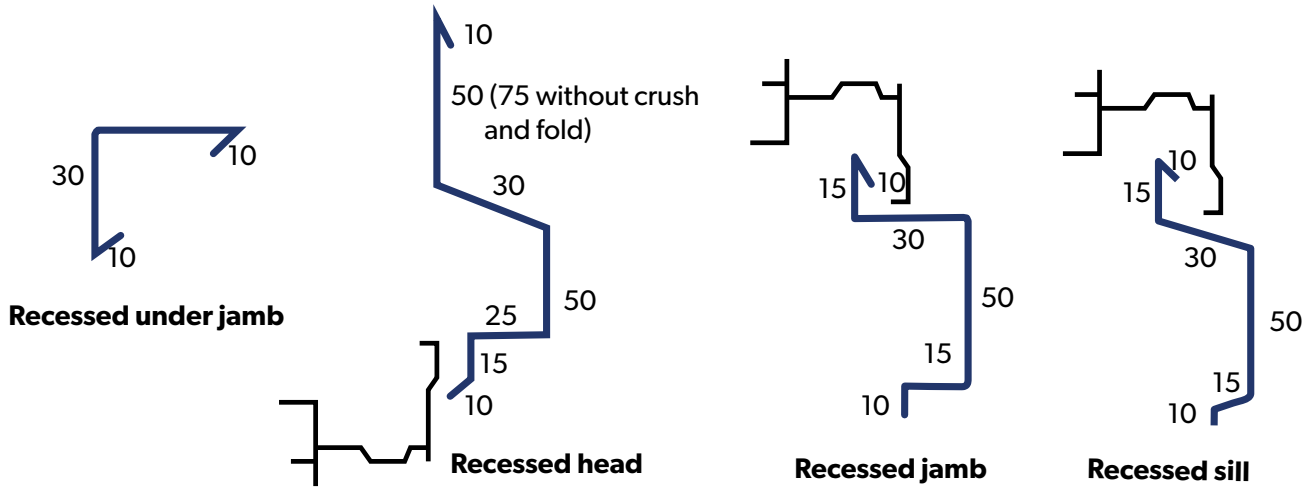


**Figure 4.14.4**  
Flush window sill flashing

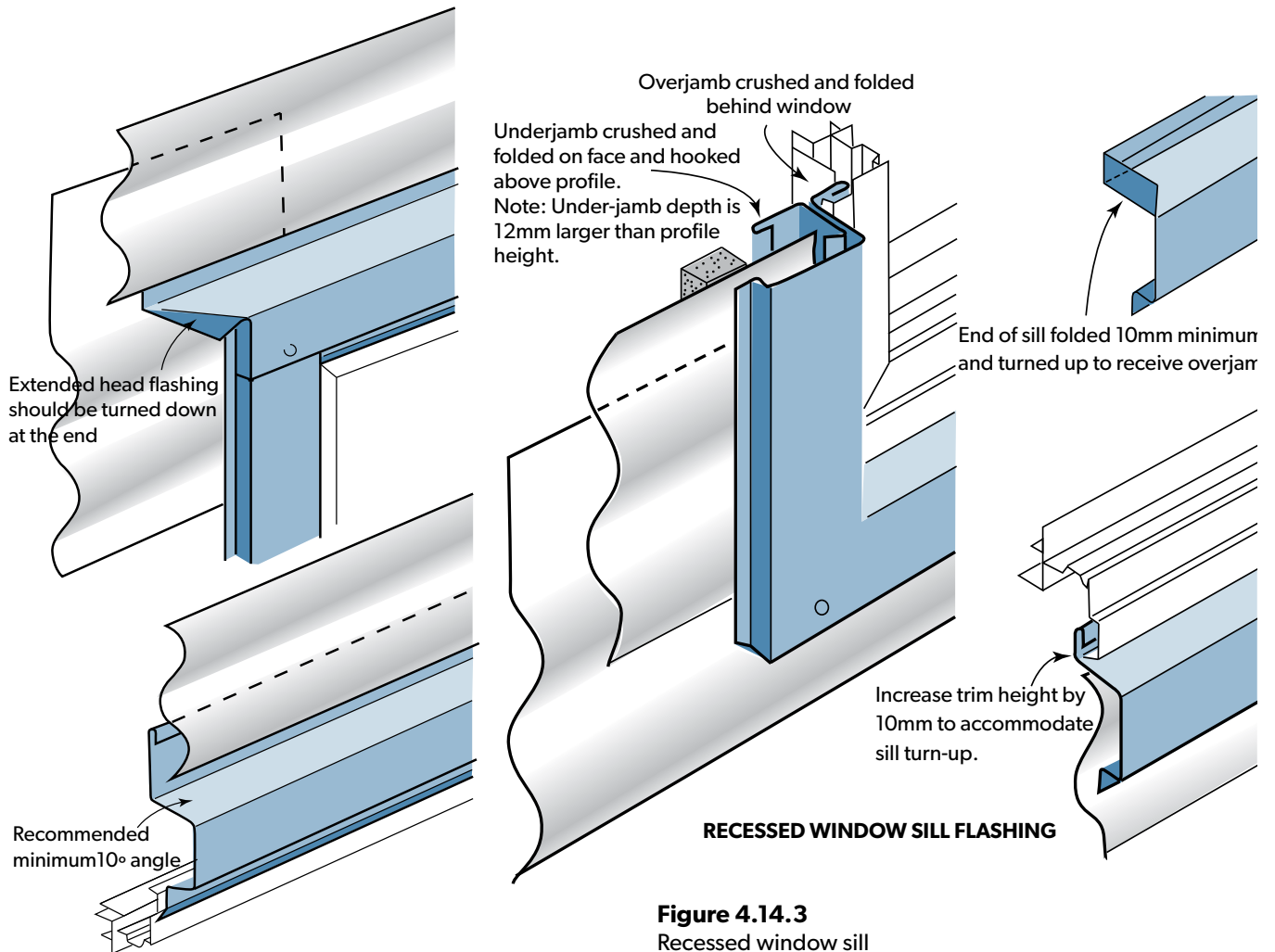
## 4.15 Recessed window flashings

A recessed window flashing design is considered the best option for horizontal cladding but accurate flashing measurement and installation are required to provide weather-tightness.

N.B. For lined buildings a cavity is required for horizontal metal cladding.



**Figure 4.14.1**  
Recessed window flashings



**Figure 4.14.3**  
Recessed window sill

**Figure 4.14.2**  
Recessed window head

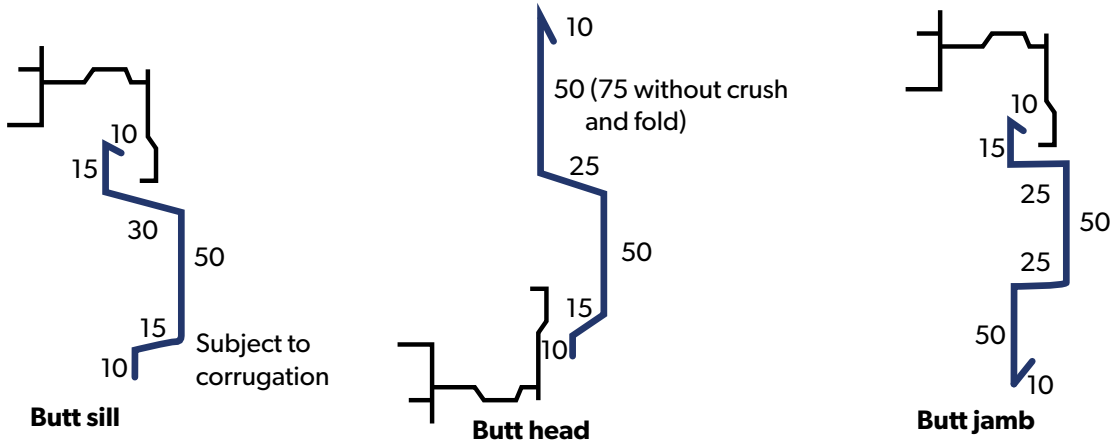
These drawings are based on drawings from the NZ METAL ROOF AND WALL CLADDING CODE OF PRACTICE (Version 2.2: 2012).

### 4.16 Butt window flashings

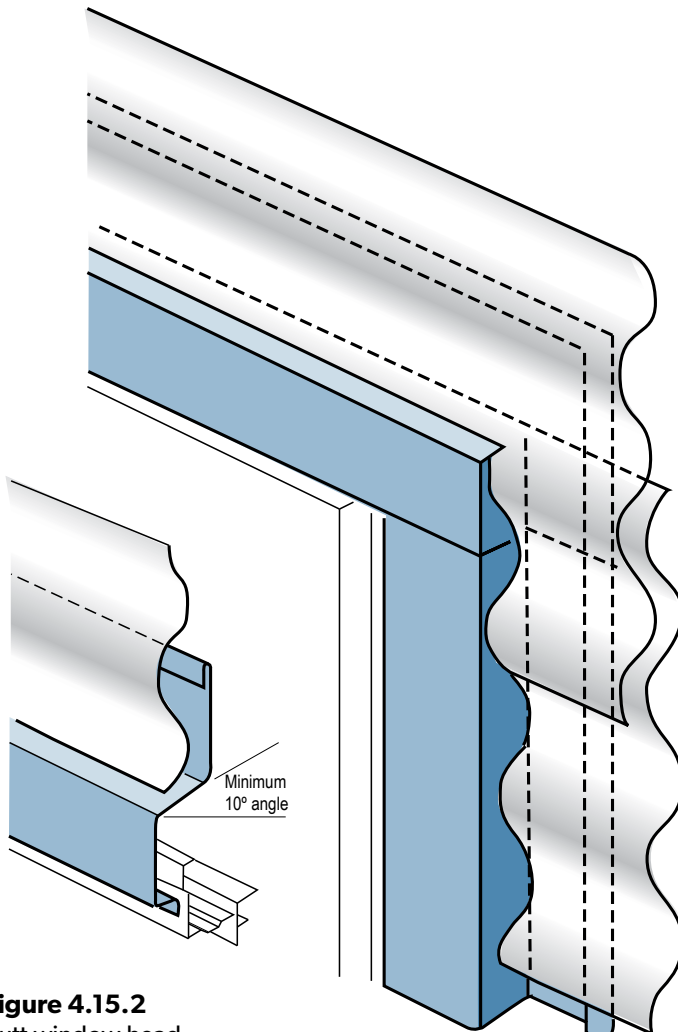
In some instances, the cladding can terminate up to a flashing without overflashing, but this requires accurate fitting to be weather-resistant. (see Figure 4.15.2). Called 'butt flashings' they can be used on flush or recess designs with a one-piece jamb. They are not suitable for areas with high wind design loads. Careful attention to design, measurement and precision manufacture are all necessary to provide a weather-resistant solution.

Additionally, butt flashings require precise and accurate installation to provide an aesthetically agreeable solution. Consideration should be given to the size of the catchment area they drain and whether adequate framing structure exists to fix them correctly. Given all these factors, they are not a preferred detail.

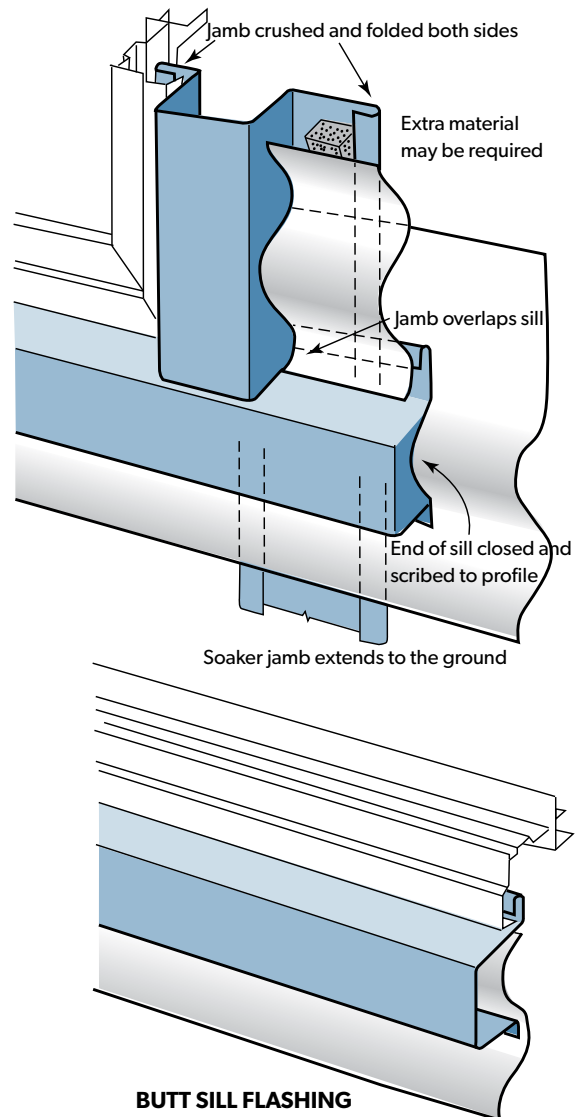
Drainage from multi-storey building can be considerable. A rule-of-thumb is to calculate this by multiplying the width of the window opening by half the height. Treat water disposal at a butt flashing as you would a penetration.



**Figure 4.15.1**  
Butt window flashings (underlay is omitted for clarity)



**Figure 4.15.2**  
Butt window head



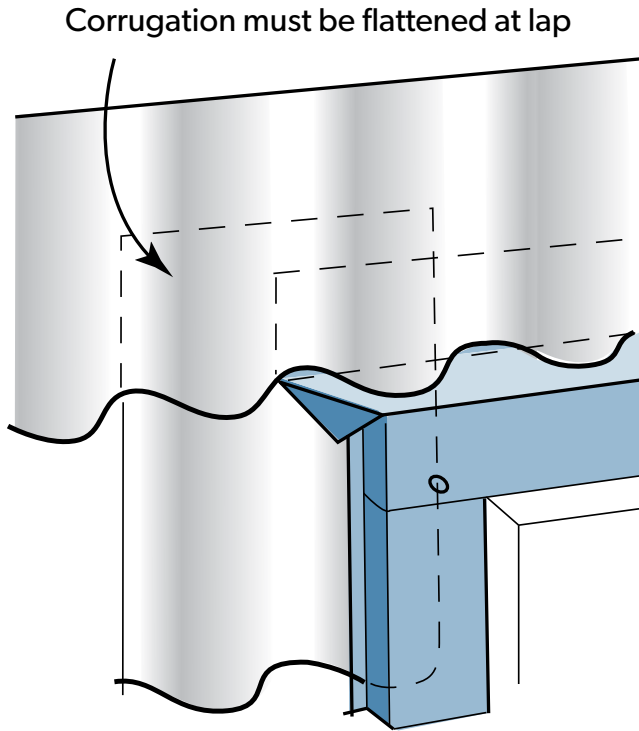
**Figure 4.15.3**  
Butt window sill flashing

These drawings are based on drawings from the NZ METAL ROOF AND WALL CLADDING CODE OF PRACTICE (Version 2.2: 2012).

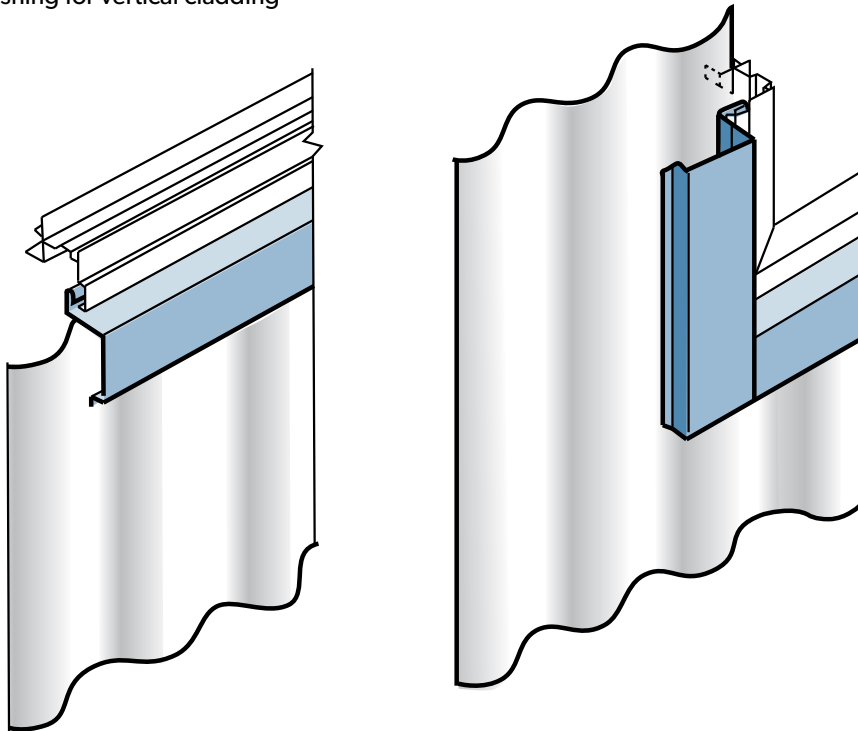
## 4.16 Flashings for vertical cladding

A cavity is not required for vertical cladding. Window and door flashings for vertical or horizontal cladding are similar. The main difference is that the module is running horizontally.

Some flexibility is required if the flashings are to be equal on both sides. Therefore, the trimming size of the window opening should have an additional 50% of the module dimension to allow for adjustment to equalise both sides.



**Figure 4.16.1**  
Head flashing for vertical cladding



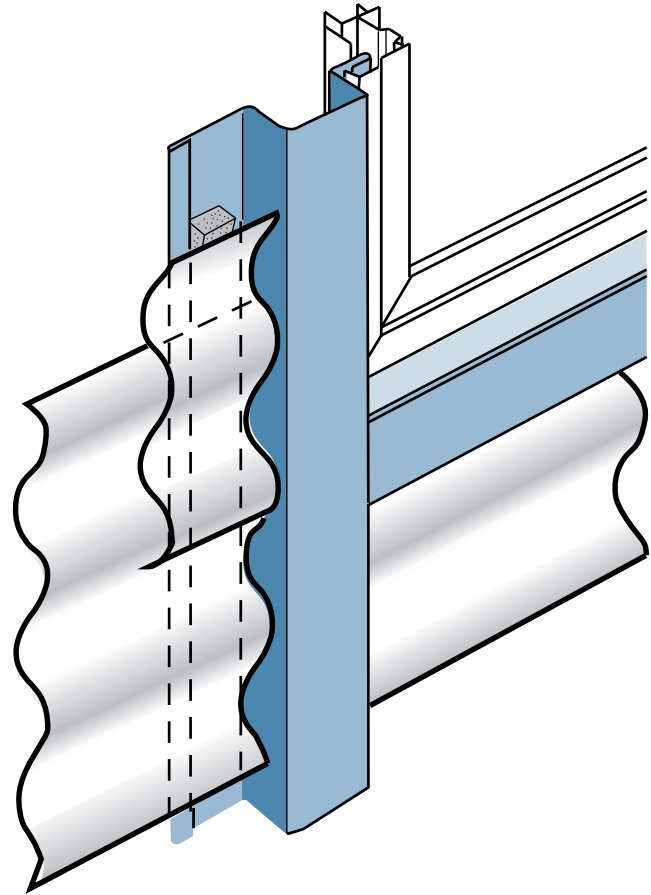
**Figure 4.16.2**  
Sill flashing for vertical cladding

## 4.17 Alternative Flashing designs

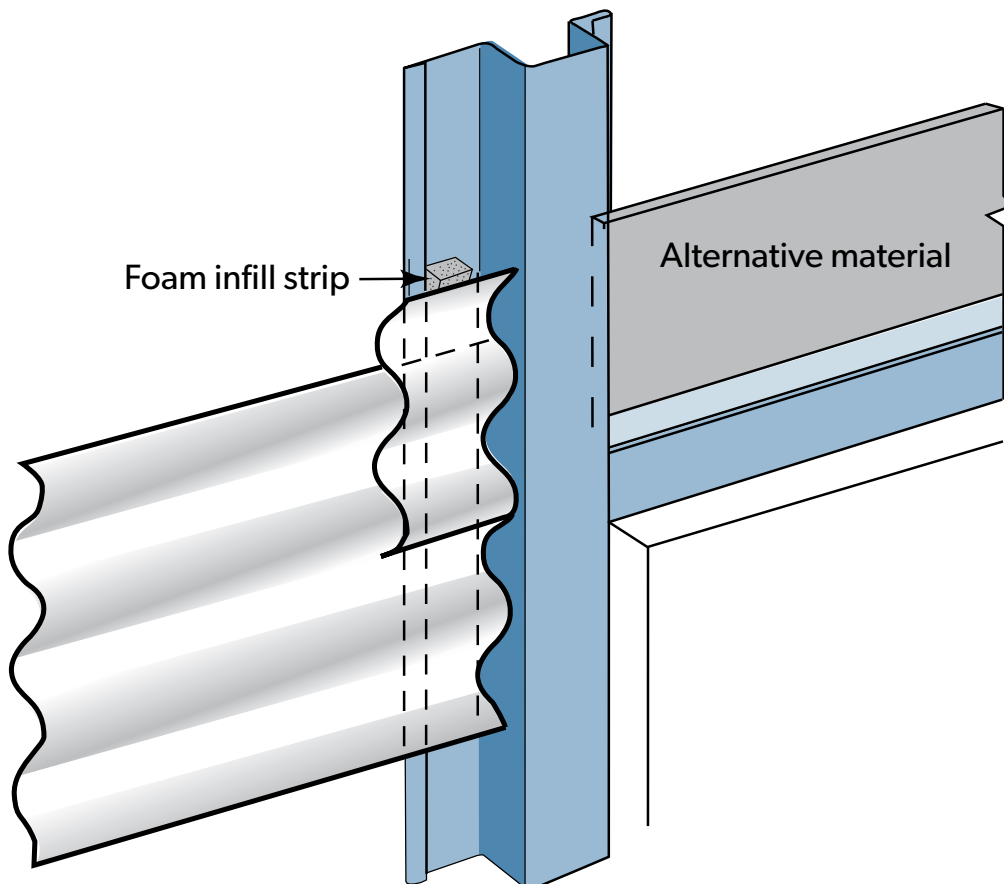
This document does not claim to be comprehensive - there are many alternate ways to successfully use butt flashings to to weather-proof a window.

If it is a 'panelised' opening, the vertical jamb flashing can be extended from soffit to the ground for single storey buildings or to a module break in a multi-storey building as shown in drawing 4.16.1.

This alternative provides the opportunity to use the same or an alternative material at the head and sill areas and a top hat flashing is used to obtain a module break.



**Figure 4.17.1**  
Alternative flashing designs



**Figure 4.17.2**  
Alternative flashing designs

## Product Descriptions

All descriptions, specifications, illustrations, drawings, data, dimensions and weights contained in this catalogue, all technical literature and websites containing information from Lysaght are approximations only.

They are intended by Lysaght to be a general description for information and identification purposes and do not create a sale by description. Lysaght reserves the right at any time to:

- (a) supply Goods with such minor modifications from its drawings and specifications as it sees fit; and
- (b) alter specifications shown in its promotional literature to reflect changes made after the date of such publication.

## Disclaimer, warranties and limitation of liability

This publication is intended to be an aid for all trades and professionals involved with specifying and installing LYSAGHT products and not to be a substitute for professional judgement.

Terms and conditions of sale available at local Lysaght sales offices.

Except to the extent to which liability may not lawfully be excluded or limited, BlueScope Steel Limited will not be under or incur any liability to you for any direct or indirect loss or damage (including, without limitation, consequential loss or damage such as loss of profit or anticipated profit, loss of use, damage to goodwill and loss due to delay) however caused (including, without limitation, breach of contract, negligence and/or breach of statute), which you may suffer or incur in connection with this publication.

© Copyright BlueScope Steel Limited 7 April, 2014

**WWW.LYSAGHT.COM**

Technical enquiries: [steeldirect@bluescopesteel.com](mailto:steeldirect@bluescopesteel.com)  
or call 1800 641417

LYSAGHT®, COLORBOND®, GALVABOND®, CUSTOM ORB®, CUSTOM BLUE ORB®, CUSTOM ORB ACCENT®, EASYCLAD®, MINI ORB®, MULTICLAD®, FLATDEK®, PANELRIB®, INTEGRITY®, TRIMWALL®, SPANRIB®, WALLCLAD®, LONGLINE®, TRIMLINE®, SHEERLINE®, TRIMDEK®, SPANDEK®, KLIP-LOK® & ZINCALUME® are registered trademarks of BlueScope Steel Limited, ABN 16 000 011 058. RoofZips® is a registered trademark of ITW Buildex. The LYSAGHT® range of products is exclusively made by or for BlueScope Steel Limited trading as Lysaght.

Digital Download 7/4/14

