

Technical Solution Sheet 0.03

0: Roof Plumbing

Flashing Roofs to Walls

AIM

The aim of this technical solution is to advise roofing practitioners of approved methods and options to install and affix wall flashings including pressure flashings where appropriate (see Figures 1, 2 and 3).

PLUMBING REGULATIONS 2008

The *Plumbing Regulations 2008* specifies that roofing (stormwater) work must comply with *SAA HB39 Installation code for metal roofing and wall cladding*. The code contains a section on “Roof flashings and cappings”.

FIGURE 1 – TRADITIONAL RAKED JOINT AND STEP METHOD

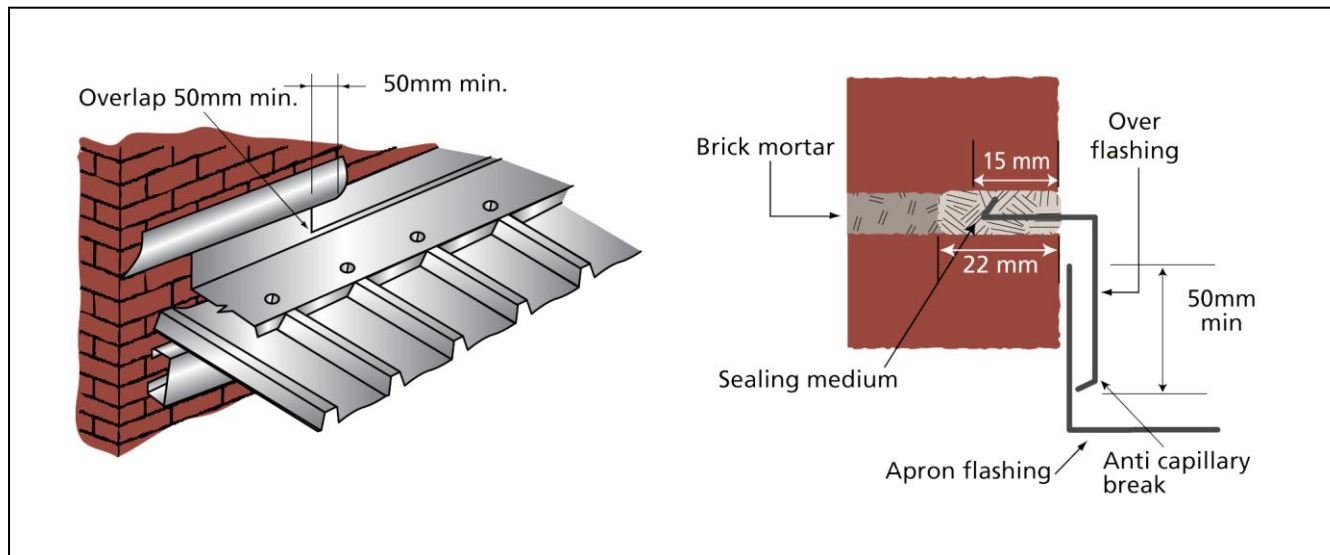
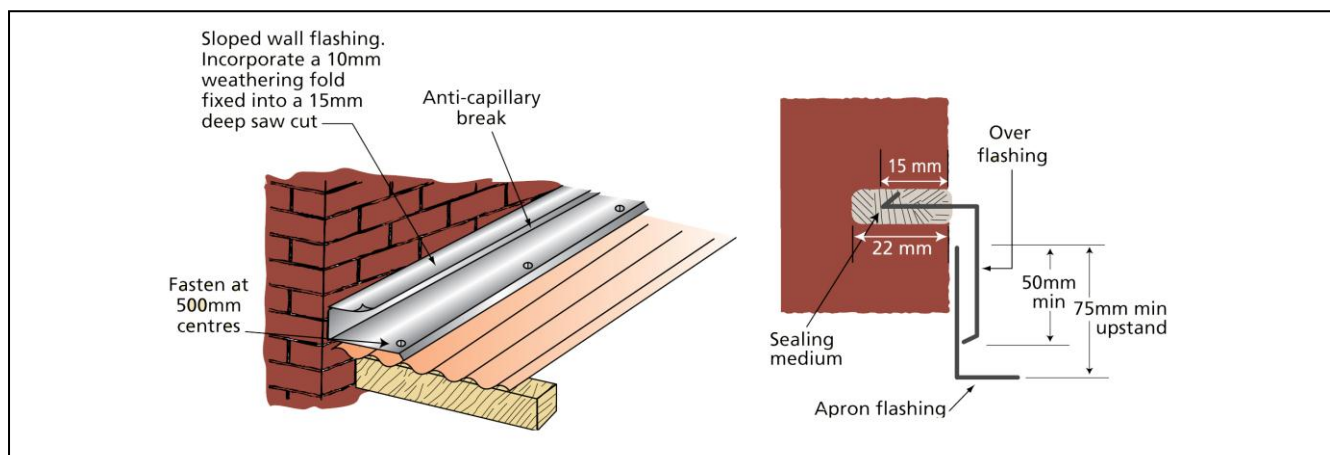
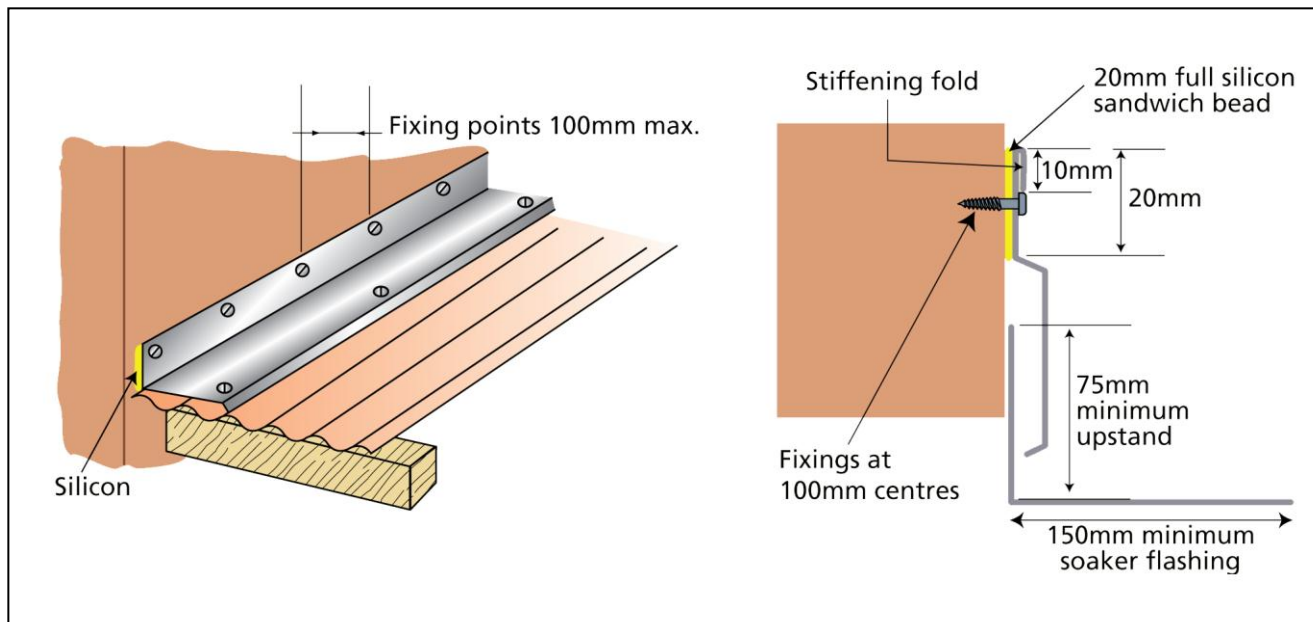

FIGURE 2 – SLOPPING WALL CUT METHOD



Technical Solution Sheet 0.03

FIGURE 3 – PRESSURE FLASHING



NOTES ON PRESSURE FLASHINGS

Pressure flashings will only be permissible against a flush surface e.g. smooth finished concrete or smooth finished brickwork with flush pointed mortar courses, provided that the following conditions apply:

- The sealant is applied in a sandwiched seal of approximately 20mm in width
- The fixing of the flashing will ensure that a durable seal is maintained
- The seal is protected from any excessive movement due to expansion or contraction
- The fixing intervals have no more than 100mm spacing
- The fixing devices are compatible with the flashing material and comply with the installation requirements of [SAA HB39](#).

GENERAL NOTE ON FIXING TO BRICK OR CONCRETE WALLS

Where flashings are large, they are particularly susceptible to movement due to wind pressures, and expansion and contraction. Large flashings should be avoided, however where necessary, should be fixed to brick or concrete walls using compatible expanding metal masonry anchors neatly encapsulated in neutral.