

This sheet deals with how to install insulation in various types of construction, providing:

- > Installation tips.
- > Typical solutions.

This sheet should be read in conjunction with **Introduction to Insulation**.



INSTALLATION TIPS

This section demonstrates how to install insulation without compromising its effectiveness.

THERMAL BRIDGES

The **building frame** can act as a thermal bridge, particularly in cold climates, conducting heat and allowing it to bypass otherwise effective insulation. Metal framing is a particular issue because of its high conductivity. The presence of the frame reduces the overall insulation value, as the frame can constitute up to 15 percent of the wall, ceiling or floor surface. To help overcome the effect of thermal bridging:

- > Use 10mm polystyrene isolating strips between the frame and the cladding.
- > Fix bulk insulation such as polystyrene boards over the external or internal surface of the frame.

VAPOUR BARRIERS

Vapour barriers include polythene sheet, reflective foil, foil backed plasterboard and well maintained water resistant painted surfaces. Water resistant insulation such as polystyrene can also act as a vapour barrier. Tape and glue all joints in vapour barriers to keep out moisture.

Use vapour barriers to protect from condensation:

- > In hot humid (tropical) climates.
- > In cool climates where the difference between indoor and outdoor temperature is significant.
- > In roof spaces with a low ventilation rate, for example cathedral or raked ceilings.

- > In situations where high amounts of vapour are generated and not exhausted.
- > On the underside of metal roofing, to minimise the likelihood of corrosion.

Install vapour barriers on the 'warm' side of the insulation.

In cold climates place the vapour barrier on the inside of the insulation (directly above the ceiling lining and next to the internal wall lining).

In warm climates place the vapour barrier on the outside of the insulation.

ROOF VENTILATION

Ventilate the roof space where possible to allow built up heat to dissipate. Even in cooler climates a minimal amount of ventilation is desirable to allow built up moisture to escape. Sufficient ventilation is often achieved through the air gaps along the ridgeline or between tiles. Gable or eaves vents may also be used.

Ventilated roof spaces in hot humid (tropical) climates under metal roofing can result in excessive condensation at night. Condensation dripping off the underside of metal roofing onto the ceiling can be avoided by installing reflective foil sarking similar to that used under roof tiles.

In bushfire prone areas cover any openings with fine stainless steel mesh to prevent cinders from entering the roof space. Keep roof spaces weather tight and vermin proof.

GAPS

Avoid gaps in all types of insulation. Even a small gap can greatly reduce the insulating value. Fit batts snugly and don't leave gaps around ducts and pipes. Tape up holes and joints in reflective insulation. Make sure the ends of multi cell and concertina foils are well sealed. Ensure that corners of walls, ceilings and floors are properly insulated as these are areas where heat leaks most often occur.

For safety reasons, clearances must be left to hot objects such as flues from fires, recessed downlights and their transformers. See Health and Safety tips following page.

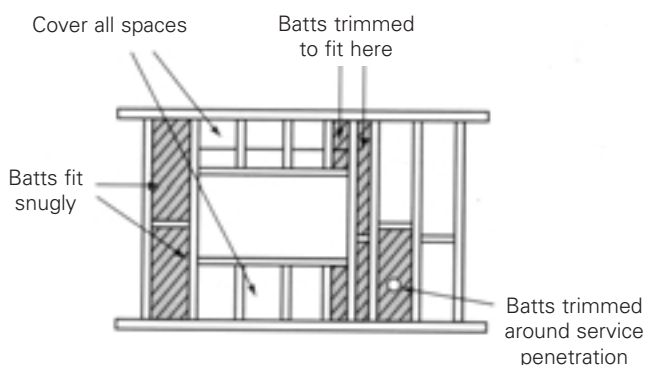

Wall insulation must butt into door and window frames. In cold climates, metal frames around glazing should have thermal breaks to reduce heat loss. [See: [Glazing Overview](#)]

Insulate internal walls between the house and uninsulated spaces such as garages and storerooms.



BULK INSULATION

Do not compress bulk insulation as this will reduce its effectiveness. Ensure there is sufficient space for the insulation to retain its normal thickness.

Keep moisture away from bulk insulation, or its performance will be reduced (water resistant types are an exception). Use a vapour barrier where there is a risk of condensation.

Restrain bulk insulation in cavities so it does not come into contact with the porous outer skin of the wall. This can be done with perforated RFL (reflective foil laminate), a non-corrosive wire or nylon fishing line.

Cavity fill insulation (loose fill or injected foam) is particularly useful for insulating existing cavity walls. Check that your local building codes permit the use of cavity fill insulation.

Potential problems to be aware of include overheating of electrical cables, damp problems (if the insulation is absorbent) and moisture transfer across the cavity by capillary action. Injected foams can cause bowing of the walls in some cases.

Loose-fill insulation should not be used in excessively draughty roof spaces or ceilings with a slope of 25 degrees or more. In other applications, keep the density of the insulation consistent to avoid reducing the R-value. Note that loose-fill insulation may settle by as much as 25 percent over time. Ask your contractor for a guaranteed 'settled R-value'.

REFLECTIVE INSULATION

Maintain an air space of at least 25mm next to the shiny surface of reflective insulation. If this is not done the insulating properties will be reduced.



Dust settling on the reflective surface of insulation will greatly reduce its performance. Face reflective surfaces downwards or keep them vertical.

Use perforated reflective foil in walls and under floors when building with porous materials. The perforations prevent water droplets from penetrating but allow vapour through so that the insulation can dry if it does somehow get wet. This prevents rotting behind weatherboards or under timber floors, for example.

HEALTH & SAFETY TIPS

Electrical wiring must be appropriately sized or it may overheat when covered by insulation. Have it inspected by a licensed electrician to ensure it can be safely covered by insulation.

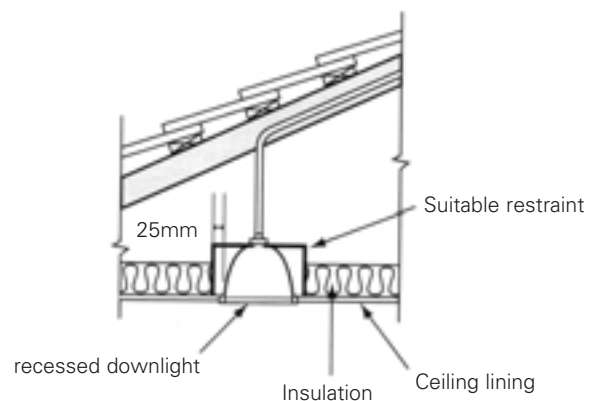

Allow clearance around appliances and fittings. Do not install insulation within 90mm of hot flues or exhaust fans, or within 25mm of recessed light fittings. (Retain a clearance of 90mm for *low voltage* downlights). Restrain loose-fill insulation with non-combustible barriers.

Wear protective clothing, gloves and a face mask when installing glass fibre, mineral wool or cellulose fibre insulation. These materials can cause short term irritation to skin, eyes and upper respiratory tract. It is good practice to always wear protective equipment when working in dusty roof spaces.

Wear adequate eye protection when installing reflective insulation, as it can cause dangerous glare. Be aware of the increased risk of sunburn.

INSTALLATION DETAILS

The following section shows typical solutions for installing insulation in various construction types. It also shows how to estimate total R values.

Total R values describe the total resistance to heat flow provided by a roof and ceiling assembly, a wall or a floor. These values are calculated from the resistances of each component, including the insulation.

Total R values are the best indicator of performance, as they show how insulation performs within the building envelope. Total R values are used when calculating HERS ratings. [See: Rating Tools]

HOW TO ESTIMATE THE TOTAL R VALUE

- > Find the construction type that relates to your situation. In the following section the total thermal resistance of the building components is given for each construction type
- > Add the material or system value of insulation you are installing. This will give you an approximate total R value

For example, adding bulk insulation with a material R value of 2.5 will increase both the up and down total R values by around 2.5, as long as the material is not compressed.

Adding reflective insulation with a system R value of 1.7up, 3.0down will increase the total up and down R values by those amounts, providing the insulation is installed as specified with air gaps.

This method provides a useful estimate, but it must be noted that many factors can reduce the total R value. These include thermal bridging, compression of bulk insulation, dust settling on reflective insulation, and the lack of a suitable air gap for reflective surfaces.

The total thermal resistance of each construction type has been calculated using information from the Australian Standard.

Total R values for roofs, ceilings and floors are expressed as up and down values. Thermal resistance to heat flowing up and heat flowing down can vary significantly.

Total R values for walls are expressed as a single figure, as heat flow in and out through walls does not necessarily correlate to heat flow up and down.

ROOF & CEILING INSULATION

Installing roof and ceiling insulation can save up to 45 percent on heating and cooling energy

PITCHED ROOFS WITH FLAT CEILINGS

This is the most common type of construction and the easiest to insulate.

Total thermal resistance of construction only:

at least R 0.35up, R 0.7down
With RFL sarking: at least R 2.2up, R 3.2down

ADDING INSULATION

Roof

A second layer of RFL (either sarking or foil batts) beneath the roof will increase resistance to radiant heat. This may be useful in hot climates. Ensure that there is at least a 25mm gap between reflective surfaces.

Place RFL sarking directly under the roofing material between the battens and the rafters with the shiny side facing down.

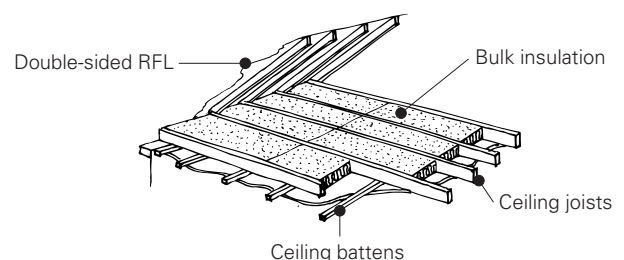

Ceiling

Place ceiling insulation between the joists.

Suitable bulk insulation includes bulk batts, loose fill and polystyrene boards. In alpine climates two layers of bulk insulation may be installed to increase thermal performance, one between the joists and the second on top.

There are cautions related to covering ceiling joists with insulation. Safe places to walk are not identifiable when accessing the roof space. If insulation is removed each time the roof space is accessed it must be reinstalled in accordance with the Australian Standard.

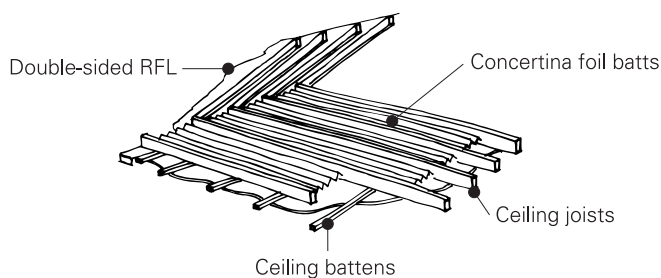

Suitable reflective insulation includes multi cell or concertina style batts. These batts can be placed between or on top of ceiling joists. Placing the batts between the joists is preferable. Install strictly in accordance with manufacturers instructions. Failure to do so can significantly reduce insulation values.

CEILINGS THAT FOLLOW THE ROOF LINE

These includes sloping ceilings, cathedral ceilings, vaulted ceilings, and flat or skillion roofs, where there is no accessible roof space.

Design ceilings with enough space to accommodate adequate insulation, including any necessary air gaps.

Ceilings with concealed rafters are easier to insulate and should be considered in preference to ceilings with exposed rafters.

Ceilings with exposed rafters require insulation products with a higher R value per unit thickness due to space limitations within the ceiling.

Consult the insulation manufacturer about installation clearances. As a rough guide, minimum batten heights for ceilings with exposed rafters are:

- > R2.0 bulk batts: 100mm
- > R2.0 polystyrene boards: 50mm

Use sarking or foil backed insulation under metal roofs.

Total thermal resistance of construction only:

Metal roof

With RFL sarking approximately R 1.0up, R1.9down

Tile roof

With RFL sarking approximately R 0.7up, R1.7down

Note that thermal resistance varies with roof pitch and the depth of reflective air spaces.

[see the Australian Standard for further information on calculating thermal resistances]

ADDING INSULATION

Similar insulation techniques are used for tile and metal roofs.

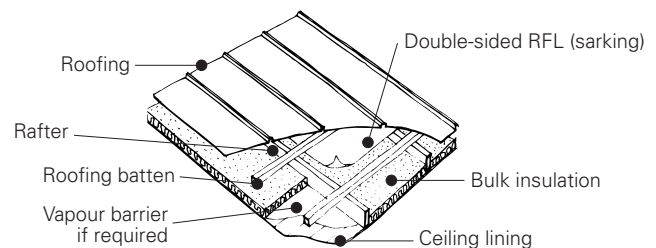

Concealed rafters

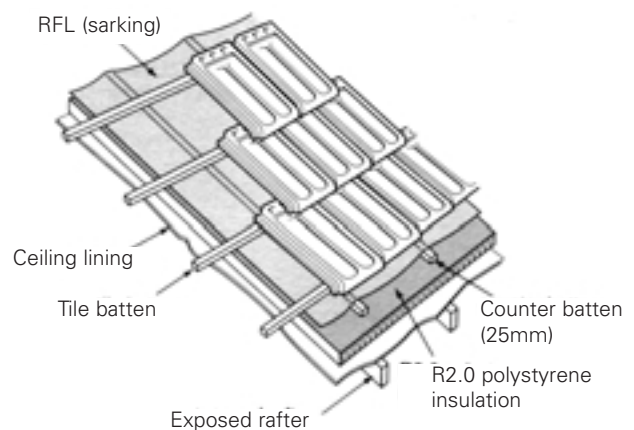

Exposed rafters

Suitable bulk insulation includes polystyrene boards and bulk batts.

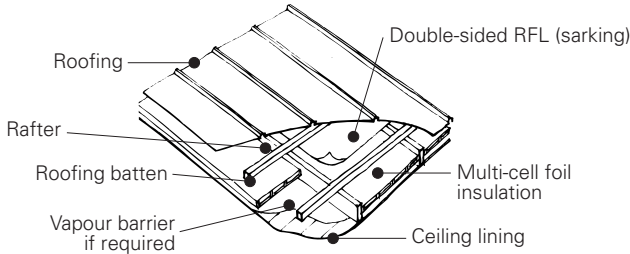

Suitable reflective insulation includes multi cell and concertina-type batts.

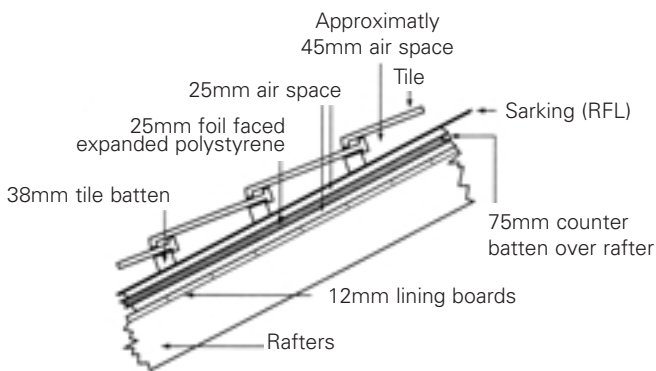

Suitable composite insulation includes foil faced polystyrene boards. If rafters are exposed, the minimum batten height is 75mm to allow for two 25mm reflective air spaces either side of the boards. 25mm foil faced polystyrene boards and RFL sarking will give a total R value of around 1.7up, 2.9down

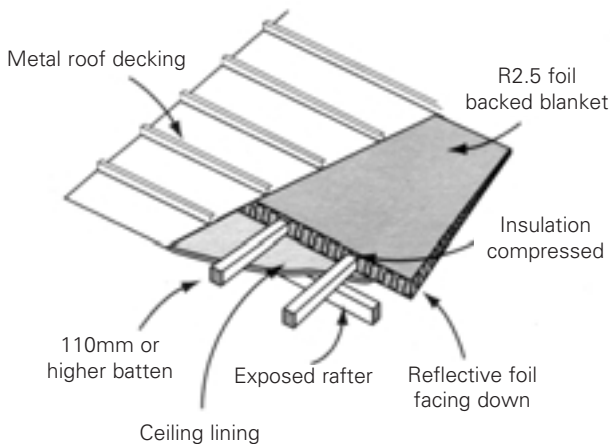

Foil backed blankets are mainly used to reduce noise from metal roofing and to provide a vapour barrier, but they are sometimes used as thermal insulation. Compression of the blanket over the battens lowers the total R value.

EXTERNAL WALL INSULATION

Insulating your walls will save up to an extra 15 percent on heating and cooling energy.

FRAMED WALLS

Brick veneer, fibre cement & weatherboard.

Weatherboard walls

Total thermal resistance of construction only:

at least R 0.45

With RFL sarking: at least R 0.9

ADDING INSULATION

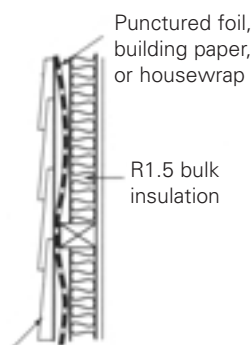

External weatherboards

Use perforated reflective foil over the outside of the frame. For higher insulation levels, add reflective foil batts between the studs. Make sure that the air spaces between reflective surfaces is at least 25mm.

Alternatively, use bulk insulation with perforated building wrap. Ensure batts fit within the cavity without compression.

Brick veneer walls

Total thermal resistance of construction only:

at least R 0.45

With RFL sarking: at least R 1.4

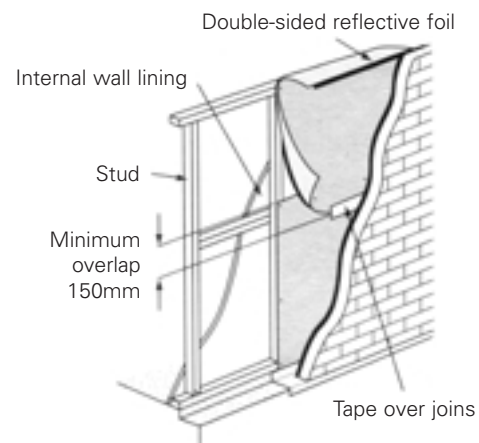

ADDING INSULATION

For higher insulation levels, add reflective batts between the studs, making sure that air spaces between each reflective surface are at least 25mm.

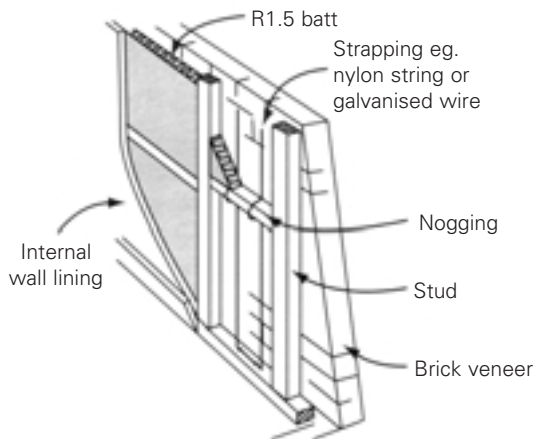

Use bulk insulation with strapping or perforated building wrap over the outside of the frame to prevent batts from touching the porous brick skin.

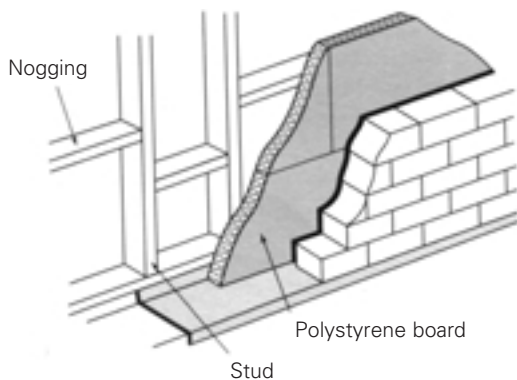

Fixing insulation to the outside of the studs is useful in cold climates to reduce thermal bridging. Placing the insulation on the outside gives a higher total R value than placing the insulation between the studs.

Suitable materials include polystyrene boards, high density rockwool batts, and foil faced polystyrene boards with a reflective air space of at least 25mm. Leave sufficient space for bricklayers to lay the outside skin (about 35mm).

CAVITY BRICK WALLS**Total thermal resistance of construction only:**

at least R 0.5

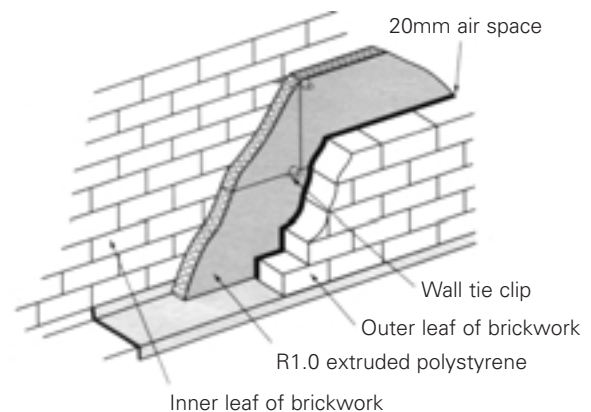
ADDING INSULATION

Use polystyrene boards or cavity fill (loose fill or injected foams).

There are various issues associated with the use of cavity fill insulation. This method is mainly used to insulate existing cavity brick walls. Check that local building regulations allow use of cavity fill. Cavity fill must be treated to be water repellent. [\[See: Insulation Overview\]](#)

Using cavity fill in double brick walls will provide a total R value of around R1.3 (dependent on cavity width).

SOLID WALLS

Including concrete block, concrete panel, mud brick, pise and solid brick construction without a cavity.

Total thermal resistance of construction only:

300mm adobe block wall approximately R 0.4

200mm concrete block wall (unfilled): R 0.39

100mm solid concrete wall approximately R 0.27

110mm brick wall approximately R 0.3

ADDING INSULATION

Solid walls can be insulated on the inside or the outside. Do not insulate the *inside* of walls whose thermal mass is to be utilised. Insulation isolates the thermal mass from the interior, wasting its beneficial passive heating potential.

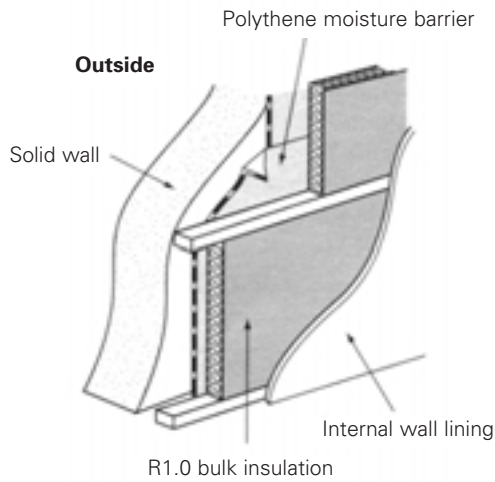

Suitable materials include polystyrene boards, bulk batts, and foil faced polystyrene with a still air layer of at least 25mm each side. For internal walls plasterboard products incorporating polystyrene are also suitable.

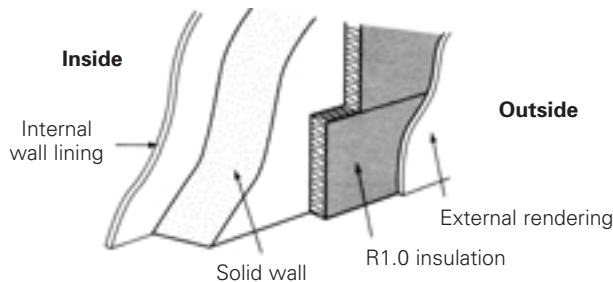

On external walls, polystyrene can be clad with an external finish, for example render. No additional waterproofing is required. Fix bulk batts between battens and cover with a waterproof cladding.

FLOOR INSULATION

SUSPENDED FLOORS

In cool climates, some mixed climates, and hot climates where airconditioning is used:

- > Enclose the sub floor space if possible [maintain sufficient ventilation to satisfy local building requirements].
- > Where appropriate install underlay and carpet, or lay insulation board under floor finishes.
- > Insulate the underside of timber floors or suspended slabs exposed to outside air.
- > Insulate the underside of heated suspended slabs.

Timber floors

Total thermal resistance of construction only:

at least R 0.3 up, R 0.4 down
With RFL: at least R 0.6 up, R 1.0 down

ADDING INSULATION

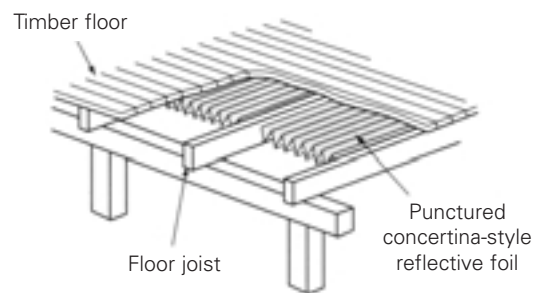

Use perforated RFL foil or concertina-type batts, stapled to the joists.

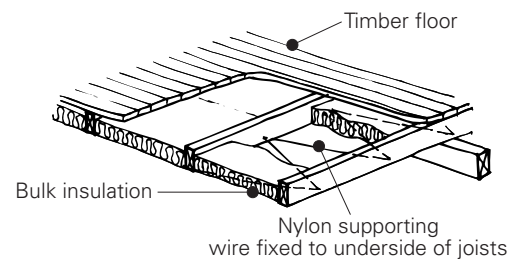

Add bulk insulation under the floor, supported by nylon cord or wire as shown.

Suspended concrete slabs

Total thermal resistance of construction only:

at least R 0.3 up, R 0.4 down

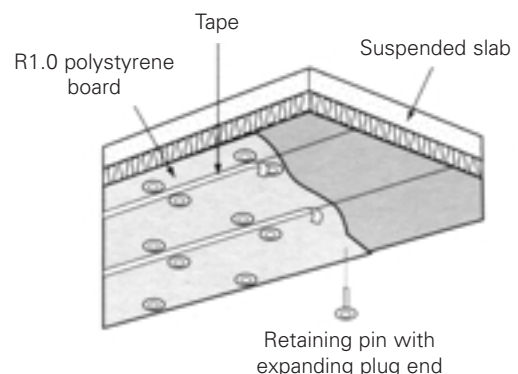

Add polystyrene boards, or foil faced polystyrene boards. Special fixings should be used with foil faced boards to allow a still air layer between the insulation and the slab.

insulation installation

Design for lifestyle & the future

Home

GROUND SLABS

Insulate ground slabs in cool climates only.

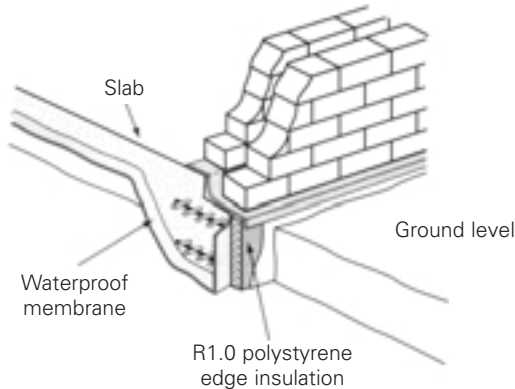

Slab edge insulation is usually sufficient, as approximately 80 percent of the heat loss occurs through the edge. Install edge insulation before the slab is poured. Do not install insulation under concrete edge beams.

Follow the manufacturers directions, particularly regarding the placement of the insulation in relation to the waterproof membrane. In termite prone areas precautions may be needed. Consult your local building information centre.

R1.0 polystyrene boards on the slab edge give a total R value of at least 2.2 [insulated section only]

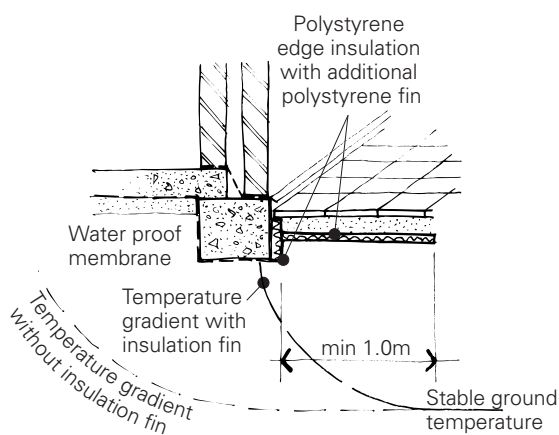

For more effective performance, extend an additional fin of polystyrene horizontally from the slab edge as shown.

The fin should extend between 1-1.5m and can be laid under external paving. The presence of the fin affects ground temperature gradients, resulting in more stable ground temperatures below the slab.

The fin is easy to install and can be done as a retrofit to existing slabs. It will not interfere with the load carrying capacity of the footings.

Insulate the underside of ground slabs where groundwater is present. This method can also be used in alpine climates and where slab heating is used, although the 'fin' method above may be just as effective. Insulation under slabs must have a high compressive strength and be resistant to moisture penetration and rotting. If the material is compressed it will no longer act as an insulator and can even lead to structural failure. Some waffle pods can be used for under-slab insulation, as long as they meet the above criteria.

ADDITIONAL KEY REFERENCES

Standards Australia, AS 2627.1-1993 *Thermal Insulation of Dwellings- Thermal insulation of roofs/ceilings and walls in dwellings*

Standards Australia, AS 3999 *Thermal Insulation of Dwellings- Bulk Insulation Installation Requirements*

Standards Australia, AS/ NZ 4200.2-1994 *Pliable building membranes and underlays. Part 2: Installation Requirements*

Sustainable Energy Authority Victoria, *Insulation Guide, 2000*

PATHE, *Insulation Management Guide for Residential Building*

Australian Govt. Publishing Service, *Energy Efficient Australian Housing, 1992*

BDP *Environment Design Guide, PR07 & PR08 Thermal Insulation in domestic buildings for temperate climates*

Principal author: Caitlin McGee

Contributing author: Max Mosher

Diagrams sourced from the SEAV Insulation Guide